

rayMAX 200

INFRA-RED PRODUCT RANGE

The RAYMAX series of High Performance Infra-Red LED illuminators provide class leading performance, long life and zero maintenance. They incorporate the very latest surface mount LED's to deliver excellent night-time pictures with improved optical output and outstanding reliability.

The unique Adaptive Illumination™ concept provides the flexibility to alter the angle of illumination on site to suit specific security needs and to match the camera's field of view. RAYMAX illuminators are also purpose designed to provide even output illumination.

Each unit is fitted with Active LED Life Control to carefully control LED output, delivering consistent illumination power and a projected working life of 10 years.

RAYMAX illuminators are supplied with bracket and power supply. Control features on the power supply include adjustable power output, photocell and telemetry control. RAYMAX 200 is suitable for all low light installations up to 300 metres (985ft).



ADAPTIVE ILLUMINATION™:



Narrow Angle



Wide Angle

INFRA-RED IN USE:

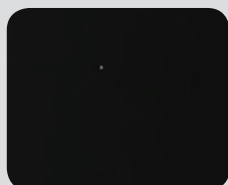

Infra-Red off



Infra-Red on

POWERFUL

- Distances up to 300m (985ft)
- Latest LED technology
- High power - low running costs

FLEXIBLE

- Adaptive Illumination™
- Various angles (10° to 180°)
- Fully Controllable Power Supply

RELIABLE

- 10 year life
- Active LED Life Control
- Vandal resistant

CONTROLLED

- Zero Light Pollution
- Even Output Illumination
- Semi-Covert (850nm) or Covert (940nm) Options

APPLICATIONS





ADAPTIVE ILLUMINATION™

Adaptive Illumination™ allows the installer to adjust the angle of the light projection from a single unit to fit the specific demands of any installation. Adjustment is quick and convenient and any angle up to 180 degrees (depending on model) is easily selectable. Adaptive Illumination is patent pending technology available exclusively from RayLED.



ACTIVE LED LIFE CONTROL

All RayLED illuminators employ cutting edge materials science techniques to improve thermal efficiency throughout the unit and ensure continuity of LED power. The New Advanced Cool Running™ system draws heat away from the LEDs, shielding the LED from abnormal stress, and allows RayLED LED products to deliver outstanding performance and consistency of illumination throughout the operational life of the illuminator.



SMT (Surface Mount Technology)

The future of lighting is surface mount LED technology. Compared to standard through hole LED's, surface mount LED's are a more robust solution increasing reliability and improving product life. They are also far more efficient at the dissipation of heat allowing the LED's to run at higher power and achieve significantly improved performance.



VANDAL RESISTANT

The polycarbonate lens design protects against severe blows from crowbars, baseball bats and can even withstand successive shots from air pistols and rifles (range dependant).



ENERGY SAVING

All RayLED illuminators use high efficiency LED's and advanced control methods to deliver extremely low electrical consumption. RayLED illuminators are energy saving and deliver huge savings in running costs compared to traditional bulb illuminators.



HIGH DEFINITION LIGHTING

High Definition Lighting allows cameras to provide crystal clear, high signal images during the hours of darkness. The breakthrough in HD lighting is made possible with RayLED's high power LED technology delivering increased power on scene.

5 YEAR WARRANTY
 All RayLED CCTV illuminators are provided with a 5 year warranty, unmatched anywhere in the CCTV lighting industry. RayLED illuminators provide guaranteed long life!



TECHNICAL SPECIFICATIONS

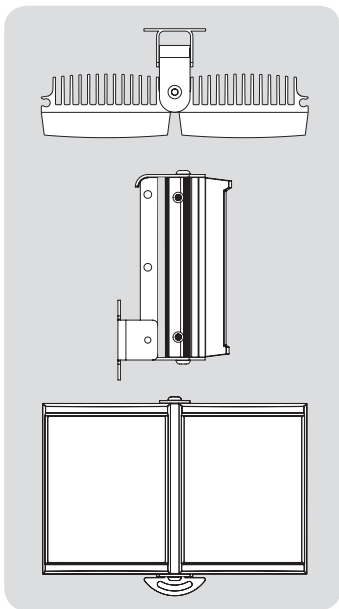

ILLUMINATOR

- Max Distance:* up to 300m (985ft)
- Angle:* Various - See Part Codes
- Optics:* SMT LED's
- Consumption:* 80W max
- Voltage:* 13.5V current controlled
- Weight:* 4kg (8.8lbs)
- Environmental:* IP66
- Temp Range:* -50 to +50°C (-58 to 122°F)
- Cable Length:* 2.5m
- Colour:* Black
- Wavelength:* 850 or 940nm
- Dimensions:* 280 x 195 x 66mm
11" x 8" x 3" approx

BRACKETRY

U Bracket and Adaptive Illumination bracket included.
 Optional pole mount and wall mount brackets available

POWER SUPPLY

- Input:* Universal 100-230V AC auto-sensing
- Output:* 80W max
- Temperature:* -50 to +50°C (-58 to 122°F)
- Weight:* 1.8kg (4lbs)
- Dimensions:* 160mm x 160mm x 90mm
6" x 6" x 4" approx

Standard PSU (Included)

Adjustable photocell
 Adjustable power output for IR
 Telemetry Control

Optional Upgrade: PRO Series PSU

PRO series PSU with optional PRO IQ and PRO Pulse plug-in modules provides user defined multi-function settings and remote control. In addition to photocell following contact and 12V DC output, PRO series features: Ecologic energy saving setting, Perma-Light consistent power setting, remote dim and boost, as well as deterrent, pulse and timer functions.

PART CODES & DISTANCES

PART CODES & DISTANCES			NARROW ANGLE	WIDE ANGLE
RM200-AI-10	RAYMAX 200, 10-20°	AI, 850nm + PSU	300m (985ft)	200m (656ft)
RM200-AI-30	RAYMAX 200, 30-60°	AI, 850nm + PSU	160m (525ft)	106m (346ft)
RM200-AI-50	RAYMAX 200, 50-100°	AI, 850nm + PSU	112m (367ft)	74m (243ft)
RM200-AI-120	RAYMAX 200, 120-180°	AI, 850nm + PSU	64m (210ft)	42m (139ft)
RM200-AI-10-C	RAYMAX 200, 10-20°	AI, 940nm + PSU	Contact RayLED	
RM200-AI-30-C	RAYMAX 200, 30-60°	AI, 940nm + PSU	Contact RayLED	
RM200-AI-50-C	RAYMAX 200, 50-100°	AI, 940nm + PSU	Contact RayLED	
RM200-AI-120-C	RAYMAX 200, 120-180°	AI, 940nm + PSU	Contact RayLED	