

rayMAX WARRIOR II

ATEX & IECEx APPROVED

EXPLOSION PROTECTED IR SERIES

The RAYMAX Warrior II series of ATEX and IECEx approved explosion protected IR illuminators have been designed for hazardous environments which require high performance night-time illumination. RAYMAX Warrior illuminators are supplied in an aluminium housing with toughened front window and are rated for all Zone 1 and Zone 2 applications.

The Warrior series IR illuminators provide class leading performance, long life and ultra low maintenance. They incorporate the very latest surface mount LEDs to deliver excellent night-time pictures with improved optical output and outstanding reliability.

Each unit is fitted with a Cool Running™ thermal management system to carefully control LED output and delivers a projected working life of 10 years. Compared to traditional bulb solutions Warrior SMT LED illuminators produce very little heat and deliver highly even illumination beam patterns.

RAYMAX Warrior illuminators are supplied with an integrated power supply and operate directly from 110-230V AC. The RAYMAX Warrior series is suitable for all low light installations up to 150 metres (492ft).

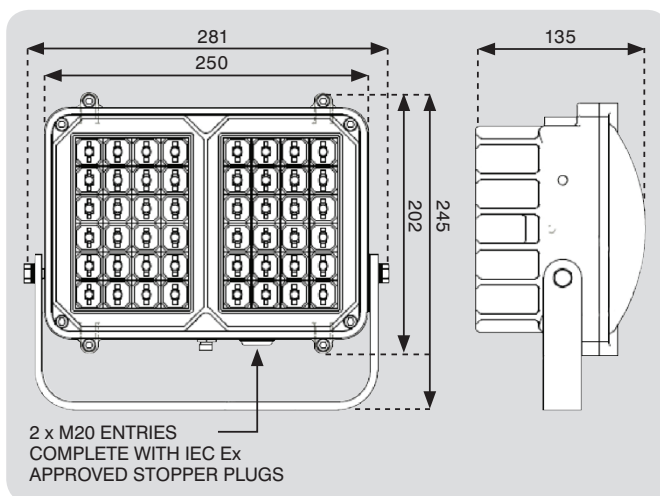

POWERFUL

- Distances up to 150m (492ft)
- **PLATINUM** LED technology
- High power - Low running costs

FLEXIBLE

- Various Angles (10° - 50°)
- Input - 110-230V
- Fully integrated power supply

RELIABLE

- 10 year life
- Cool Running™ thermal management system
- Marine grade aluminium housing with toughened window

CONTROLLED

- Suitable for Zone 1 and Zone 2 hazardous environments
- Even Output Illumination
- ATEX and IECEx approved

APPLICATIONS





PLATINUM ADVANCED SMT LED TECHNOLOGY

PLATINUM illuminators integrate cutting-edge SMT LED technology, light intensification miniature optics (LIMO) and an enhanced Cool Running™ thermal management system into a single ultra high performance LED. The result is World leading power, reliability and flexibility.



ACTIVE LED LIFE CONTROL

All RayLED illuminators employ cutting edge materials science techniques to improve thermal efficiency throughout the unit and ensure continuity of LED power. The New Advanced Cool Running™ system draws heat away from the LEDs, shielding the LED from abnormal stress, and allows RayLED LED products to deliver outstanding performance and consistency of illumination throughout the operational life of the illuminator.



VANDAL RESISTANT

The polycarbonate lens design protects against severe blows from crowbars, baseball bats and can even withstand successive shots from air pistols and rifles (range dependant).



ENERGY SAVING

All RayLED illuminators use high efficiency LED's and advanced control methods to deliver extremely low electrical consumption. RayLED illuminators are energy saving and deliver huge savings in running costs compared to traditional bulb illuminators.



HIGH DEFINITION LIGHTING

High Definition Lighting allows cameras to provide crystal clear, high signal images during the hours of darkness. The breakthrough in HD lighting is made possible with RayLED's high power LED technology delivering increased power on scene.

3 YEAR WARRANTY

All RayLED CCTV illuminators are provided with a 3 year warranty, unmatched anywhere in the CCTV lighting industry. RayLED illuminators provide guaranteed long life!

**3 YEAR
WARRANTY**

TECHNICAL SPECIFICATIONS

ILLUMINATOR & INTEGRATED PSU

<i>Max Distance:</i>	up to 150m (492ft)
<i>Angle:</i>	10, 30, or 50 degrees
<i>Optics:</i>	SMT LED's
<i>Consumption:</i>	<100W
<i>Input:</i>	110-230V AC Approx. 0.3A Internally fused
<i>Voltage:</i>	13.5V current controlled
<i>Weight:</i>	<5.6kg (12.3lbs)
<i>Environment:</i>	Zone 1 & 2 Hazardous Environments
<i>IP Rating:</i>	66/67
<i>Temp Range:</i>	-20 to +50°C (-4 to 122°F)
<i>Cable Length:</i>	2.7m
<i>Colour:</i>	Black
<i>Wavelength:</i>	850nm
<i>Dimensions:</i>	250 x 165 x 145mm 10" x 6.5" x 5.7" approx
<i>Certifications:</i>	IECEX Cert. Ex emb IIC T4 Gb Ex t IIIC T103°C Db IP66/67 Tamb -20°C to +50°C ATEX Cert. II 2 G D Ex emb IIC T4 Gb Ex t IIIC T103°C Db IP66/67 Ta = -20°C to +50°C

BRACKETRY

Wall Mount Bracket included.

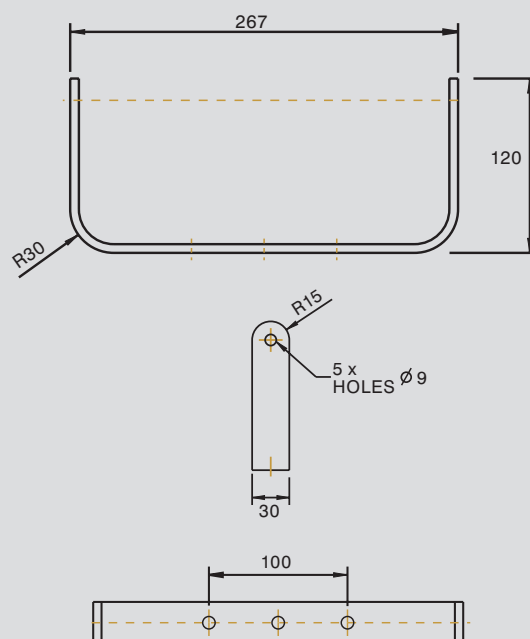

PART CODES & DISTANCES

RMW2-200-10	RAYMAX Warrior, 10°	850nm	150m (492ft)
RMW2-200-30	RAYMAX Warrior, 30°	850nm	80m (262ft)
RMW2-200-50	RAYMAX Warrior, 50°	850nm	56m (184ft)