

rayMAX 100 TWIN

PAN AND TILT ILLUMINATION SYSTEMS

PLATINUM[®] TWIN IR

The RM100 PLATINUM Twin illumination system is **designed specifically for use with pan and tilt systems**. RM100 Twin series provides World class performance, long life and ultra low maintenance. All PLATINUM illuminators incorporate the very latest surface mount LED's to deliver excellent night-time pictures with improved optical output and outstanding reliability.

RM100 Twin Systems are available in different angle variations which all deliver even output illumination. The system is supplied as two separate panels for optimal weight distribution on pan and tilt heads.

Each unit is fitted with Active LED Life Control to carefully control LED output, delivering consistent illumination power and a projected working life of 10 years.

RAYMAX illuminators are supplied with bracket and power supply. Control features on the power supply include adjustable power output, photocell and telemetry control. RM100 PLATINUM Twin illumination system is suitable for all PTZ installations up to 200 metres (656ft).

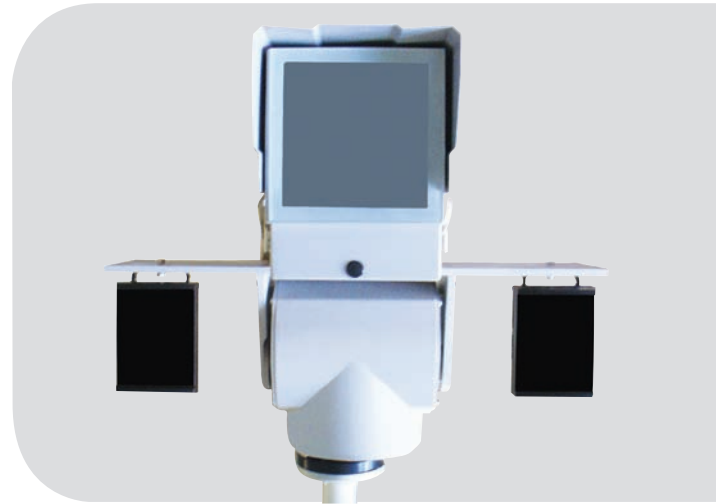

POWERFUL

- Distances up to 200m (656ft)
- **PLATINUM[®]** LED technology
- Ultra high power -
Low running costs

FLEXIBLE

- 2 Panel system for optimal weight distribution
- Mix and match angles as required (10° - 120°+)
- Fully Controllable Power Supply

RELIABLE

- 10 year life
- Active LED Life Control
- Vandal Resistant

CONTROLLED

- Zero Light Pollution
- Even Output Illumination
- Semi-Covert (850nm)

INFRA-RED IN USE:

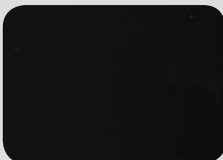

Infra-Red off



Infra-Red on

Version 3.1

APPLICATIONS





PAN AND TILT OPTIMISED

For optimal weight distribution the system is provided as 2 LED panels which can be tilted either side of the camera housing. Each panel can be any angle to deliver twin narrow illuminators or a mixed narrow and wide angle system.



PLATINUM ADVANCED LED TECHNOLOGY

PLATINUM illuminators use cutting edge SMT LED technology together with Light Intensification Miniature Optics (LIMO™) and an enhanced Cool Running™ thermal management system into a single high performance LED. The result is World leading power, reliability and flexibility.



ACTIVE LED LIFE CONTROL

All RayLED illuminators employ cutting edge materials science techniques to improve thermal efficiency throughout the unit and ensure continuity of LED power. The New Advanced Cool Running™ system draws heat away from the LEDs, shielding the LED from abnormal stress, and allows RayLED LED products to deliver outstanding performance and consistency of illumination throughout the operational life of the illuminator.



VANDAL RESISTANT

The polycarbonate lens design protects against severe blows from crowbars, baseball bats and can even withstand successive shots from air pistols and rifles (range dependant).



ENERGY SAVING

All RayLED illuminators use high efficiency LED's and advanced control methods to deliver extremely low electrical consumption. RayLED illuminators are energy saving and deliver huge savings in running costs compared to traditional bulb illuminators.



HIGH DEFINITION LIGHTING

High Definition Lighting allows cameras to provide crystal clear, high signal images during the hours of darkness. The breakthrough in HD lighting is made possible with RayLED's high power LED technology delivering increased power on scene. High definition cameras require high definition lighting.

5 YEAR WARRANTY

All RayLED CCTV illuminators are provided with a 5 year warranty, unmatched anywhere in the CCTV lighting industry. RayLED illuminators provide guaranteed long life!



TECHNICAL SPECIFICATIONS

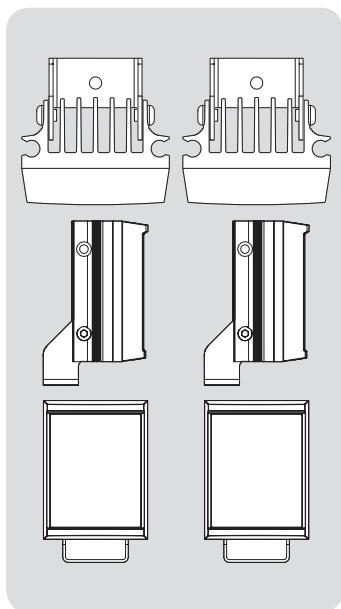

ILLUMINATOR

Max Distance: up to 200m (656ft)
Angle: Various - See Part Codes
Optics: SMT LED's
Consumption: 70W max (combined)
Voltage: 13.5V current controlled
Weight: 1kg (2.2lbs)
Environmental: IP66
Temp Range: -50 to +50°C (-58 to 122°F)
Cable Length: 2.5m
Colour: Black
Wavelength: 850nm
Dimensions: 135 x 100 x 63mm
(single panel) 5.25" x 4" x 2.5" approx

BRACKETRY

Two U Brackets included.
SB1 Single bracket for top/pan/tilt mount
DB2 Twin bracket for top/pan/tilt mount

POWER SUPPLY (to power both units)

Input: Universal 100-240V AC auto-sensing
Output: ~70W max **Temperature:** -50 to +50°C (-58 to 122°F)
Weight: 1.5kg (3.3lbs) **Dimensions:** 160mm x 160mm x 81mm
 6" x 6" x 4" approx

Standard PSU (included)
 Adjustable photocell Adjustable power output for IR Telemetry Control

Premium PSU (add ~PR to part code)
 All standard PSU features PLUS:
 Photocell following contact for switching of dual mode cameras
 12V dc output to power cameras

Pulsed PSU (add ~PU to part code)
 To pulse RayLED lights in sync with cameras. Power Adjustment Video In and Video Out connections to sync light and camera.
 12V dc output to power cameras

PART CODES & DISTANCES

PART CODES & DISTANCES			NARROW ANGLE	WIDE ANGLE
RM100-PLT-10-10	RAYMAX 100, 10+10 degree Twin PLATINUM illumination	850nm + PSU	200m (656ft)	130m (427ft)
RM100-PLT-10-30	RAYMAX 100, 10+30 degree Twin PLATINUM illumination	850nm + PSU	130m (427ft)	90m (295ft)
RM100-PLT-10-50	RAYMAX 100, 10+50 degree Twin PLATINUM illumination	850nm + PSU	90m (295ft)	58m (190ft)
RM100-PLT-10-10-C	RAYMAX 100, 10+10 degree Twin PLATINUM illumination	940nm + PSU		Contact RayLED
RM100-PLT-10-30-C	RAYMAX 100, 10+30 degree Twin PLATINUM illumination	940nm + PSU		Contact RayLED
RM100-PLT-10-50-C	RAYMAX 100, 10+50 degree Twin PLATINUM illumination	940nm + PSU		Contact RayLED