

rayMAX and rayLUX

illuminators installation guide

(including IR Covert, IR PLATINUM, HYBRID and Low Voltage Series)

This installation guide provides instructions for installing the RAYMAX and RAYLUX series illuminators

Installation Steps

1. Mount Illuminator
2. Mount Power Supply Unit (PSU)
3. Connect Illuminator to PSU
4. PSU connections
5. Connect PSU to Mains

Set Up Steps

1. Position illuminator adjacent to camera and point towards scene
2. Adjust vertical angle
3. Adjust horizontal angle via Adaptive Illumination (AI) (if required)
4. Tighten all fixings

Package Contents

1. Illuminator
2. Power Supply (PSU)

GOLDEN RULES:

1. Ensure PSU lid orientation has warning label in line with glands (see PSU diagram, right)
2. Ensure operating voltage is correct for unit being installed
3. DO NOT INPUT MAINS VOLTAGE INTO LOW VOLTAGE PSU
4. Ensure PSU is fully water tight

Overview



RAYMAX / RAYLUX illuminator

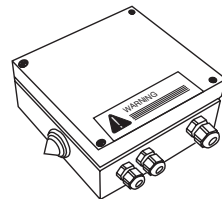

PSU

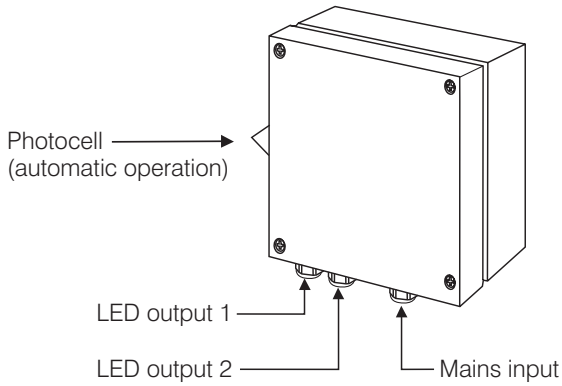
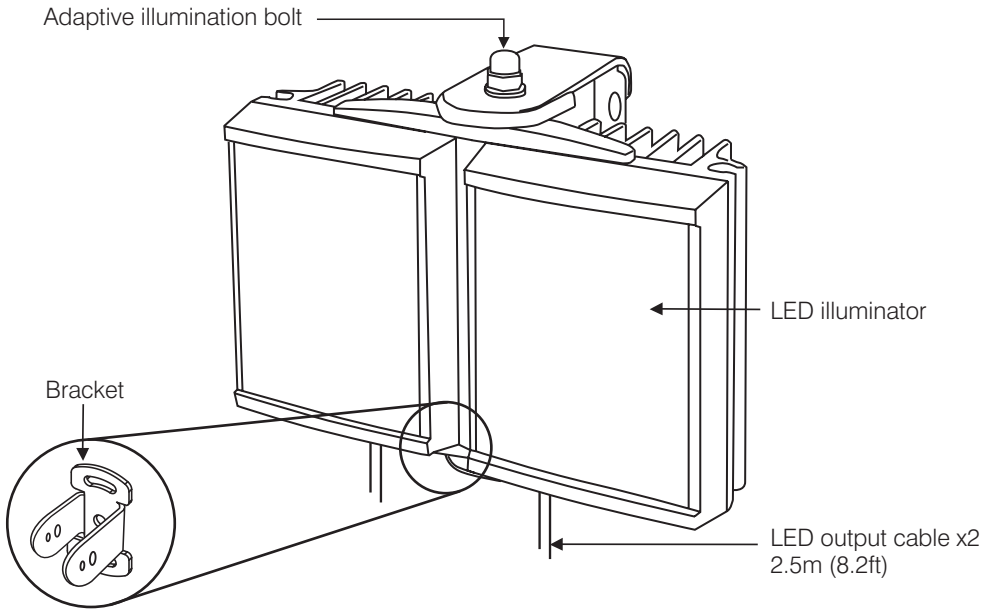

Isolate mains before removing cover	Mount PSU to flat surface	Install in a well ventilated area	Do not continually stare at lamp

Specifications subject to change without notice. Installation to be carried out by suitable trained and qualified personnel.

Installation

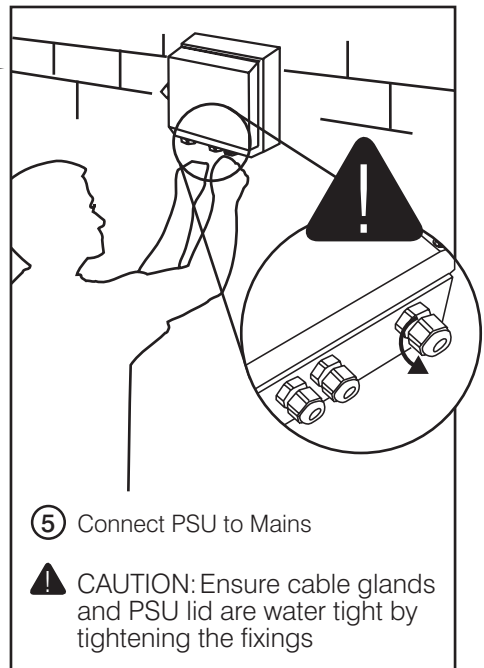
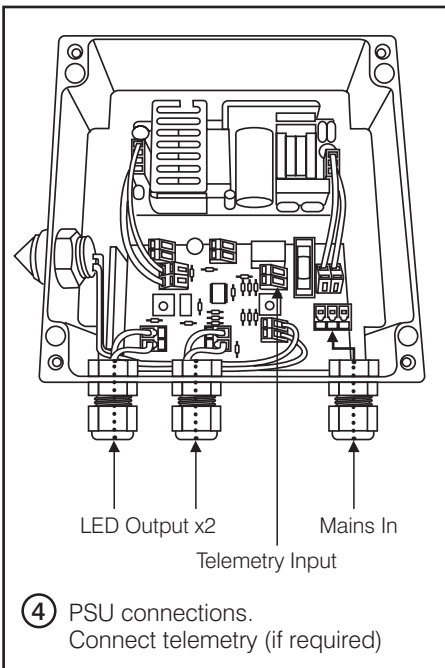
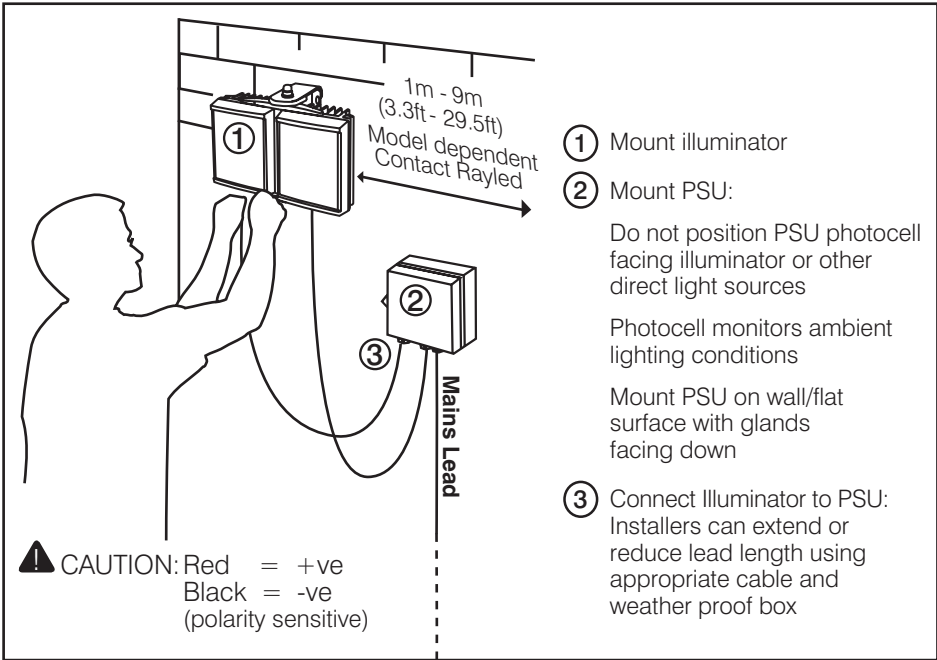

Set Up

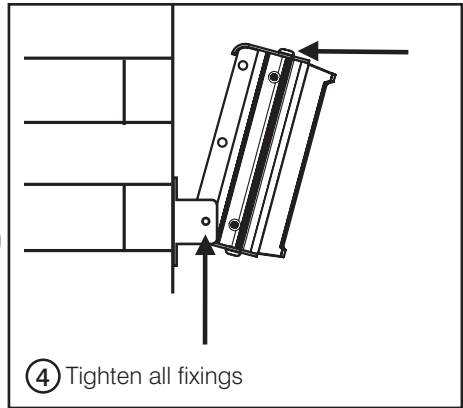
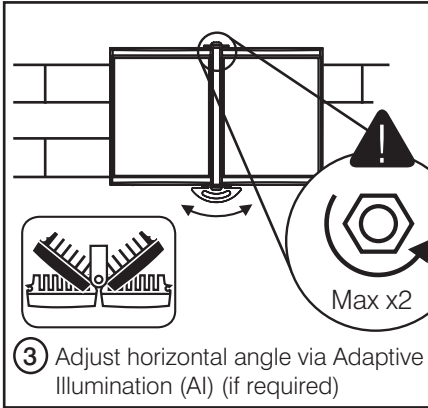
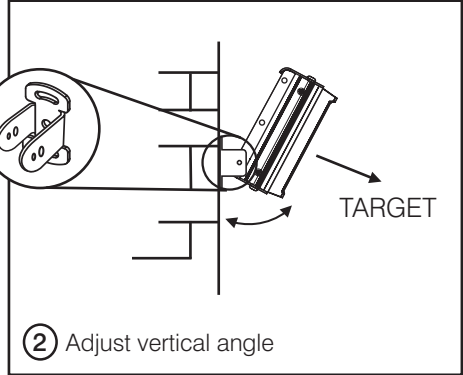
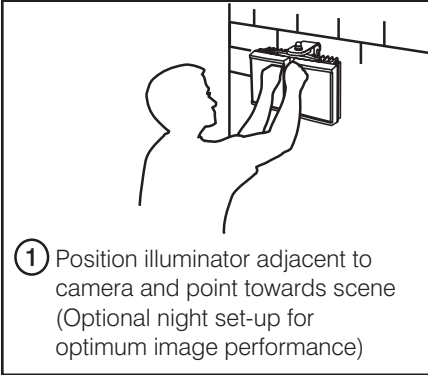

⚠ CAUTION: Do not fully loosen AI bolt.
 Note: Power adjust available if required (see PSU diagrams, pages 8-9)

Match illumination to camera field of view

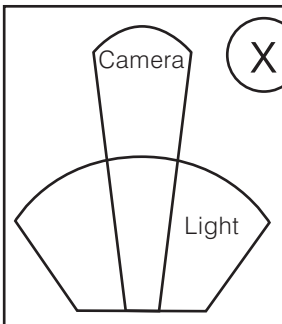

Reduces performance

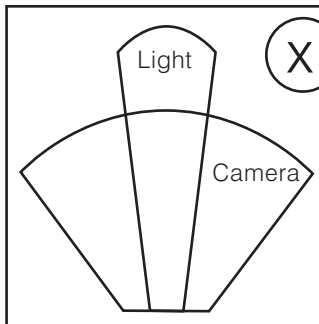

May cause hot spots

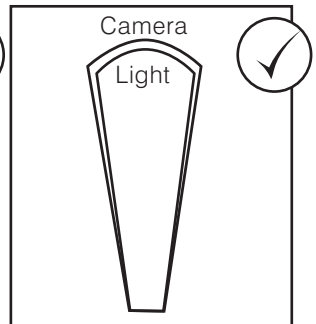

Best performance

Technical Drawings (Not to scale)

Standard Bracketry

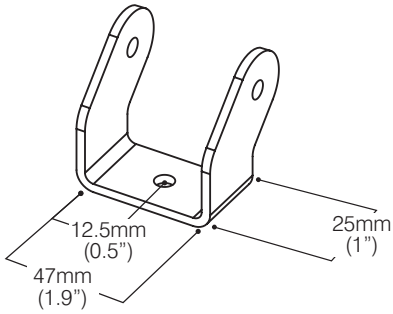

RM/RL 25

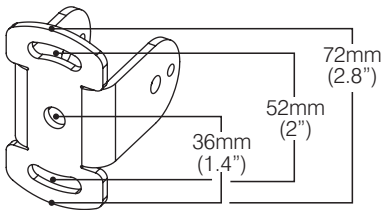

RM/RL 200/100/50

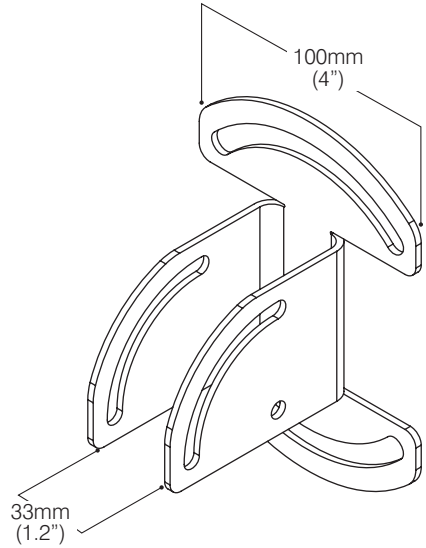

RM/RL 300/150

Optional Bracketry

Wall Mount

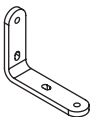

Ptz Mount

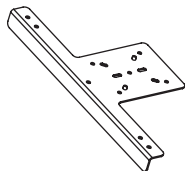

Dome Mount

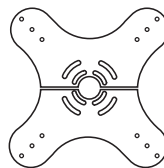

Pole Mount

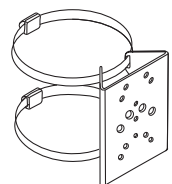

PSU Specifications

INFRA-RED Series PSU

	RM300	RM200	RM150	RM100	RM50	RM25
Input	AC 100-230 universal <120W	AC 100-230 universal <80W	AC 100-230 universal <60W	AC 100-230 universal <40W	AC 100-230 universal <20W	AC 100-230 universal <10W
Fuse	2.5A anti-surge	2.5A anti-surge	2.5A anti-surge	2.5A anti-surge	1A anti-surge	1A anti-surge
Typical Output (Standard)	6.6A @ 13.5V	4.4A @ 13.5V	3.6A @ 13.5V	2.4A @ 13.5V	1A @ 13.5V	0.5A @ 13.5V
Typical Output (IR PLATINUM)	9A @ 14V	6A @ 14V	6A @ 14V	4A @ 14V	2A @ 14V	1A @ 14V
Typical Output (IR Covert)	9A @ 14V	6A @ 14V	6A @ 14V	4A @ 14V	2A @ 14V	1A @ 14V
Adjustable Power	10% - 100%	10% - 100%	10% - 100%	10% - 100%	10% - 100%	10% - 100%
Weight	2.3 kg (5.1lbs)	1.85 kg (4.1lbs)	2.3 kg (5.1lbs)	1.65 kg (3.6lbs)	0.9 kg (2lbs)	0.8 kg (1.8lbs)
Dimensions L x W x D	240 x 160 x 81mm (9.4 x 6.3 x 3.2")	160 x 160 x 81mm (6.3 x 6.3 x 3.2")	240 x 160 x 81mm (9.4 x 6.3 x 3.2")	160 x 160 x 81mm (6.3 x 6.3 x 3.2")	130 x 130 x 60mm (5.1 x 5.1 x 2.4")	130 x 130 x 60mm (5.1 x 5.1 x 2.4")
Drilling Dimensions	4 x M4 holes @ 225 x 123mm (8.9" x 4.8")	4 x M4 holes @ 145 x 123mm (5.7" x 4.8")	4 x M4 holes @ 225 x 123mm (8.9" x 4.8")	4 x M4 holes @ 145 x 123mm (5.7" x 4.8")	4 x M4 holes @ 113 x 113mm (4.4" x 4.4")	4 x M4 holes @ 113 x 113mm (4.4" x 4.4")

WHITE-LIGHT Series PSU

	RL300	RL200	RL150	RL100	RL50	RL25
Input	AC 100-230 universal <120W	AC 100-230 universal < 80W	AC 100-230 universal <60W	AC 100-230 universal <40W	AC 100-230 universal <20W	AC 100-230 universal <10W
Fuse	2.5A anti-surge	2.5A anti-surge	2.5A anti-surge	2.5A anti-surge	1A anti-surge	1A anti-surge
Typical Output	6.3A @ 13.5V	4.2A @ 13.5V	4.2A @ 13.5V	2.8A @ 13.5V	1.4A @ 13.5V	0.7A @ 13.5V
Adjustable Power	10% - 100%	10% - 100%	10% - 100%	10% - 100%	10% - 100%	10% - 100%
Weight	2.3 kg (5.1lbs)	1.85 kg (4.1lbs)	2.3 kg (5.1lbs)	1.65 kg (3.6lbs)	0.9 kg (2lbs)	0.8 kg (1.8lbs)
Dimensions L x W x D	240 x 160 x 81mm (9.4 x 6.3 x 3.2")	160 x 160 x 81mm (6.3 x 6.3 x 3.2")	240 x 160 x 81mm (9.4 x 6.3 x 3.2")	160 x 160 x 81mm (6.3 x 6.3 x 3.2")	130 x 130 x 60mm (5.1 x 5.1 x 2.4")	130 x 130 x 60mm (5.1 x 5.1 x 2.4")
Drilling Dimensions	4 x M4 holes @ 225 x 123mm (8.9" x 4.8")	4 x M4 holes @ 145 x 123mm (5.7" x 4.8")	4 x M4 holes @ 225 x 123mm (8.9" x 4.8")	4 x M4 holes @ 145 x 123mm (5.7" x 4.8")	4 x M4 holes @ 113 x 113mm (4.4" x 4.4")	4 x M4 holes @ 113 x 113mm (4.4" x 4.4")

HYBRID Series PSU

Input	Fuse	Typical Output	Adjustable Power	Weight	Dimensions L x W x D	Drilling Dimensions
AC 100-230 universal <120W	2.5A anti-surge	Model dependent Contact Rayled	10% - 100%	2.3 kg (5.1lbs)	240 x 160 x 81mm (9.4 x 6.3 x 3.2")	4 x M4 holes @ 225 x 123mm (8.9" x 4.8")

Low Voltage PSU (LVP) Specification

INFRA-RED AND WHITE-LIGHT Series PSU

(Excluding Platinum and Covert Series)

	300	200	150	100	50	25
Input	x	24V AC/DC	x	24V AC/DC	12/24V AC/DC	12/24V AC/DC
Fuse	x	5A	x	5A	3A	3A
Typical Output (Infra-Red)	x	4.4A @ 13.5V	x	2.4A @ 13.5V	1A @ 13.5V	0.5A @ 13.5V
Typical Output (White-Light)	x	4.2A @ 13.5V	x	2.8A @ 13.5V	1.4A @ 13.5V	0.7A @ 13.5V
Adjustable Power	x	10% - 100%	x	10% - 100%	10% - 100%	10% - 100%
Weight	x	1.85 kg (4.1lbs)	x	1.65 kg (3.6lbs)	0.9 kg (2lbs)	0.8 kg (1.8lbs)
Dimensions L x W x D	x	160 x 160 x 81mm (6.3 x 6.3 x 3.2")	x	160 x 160 x 81mm (6.3 x 6.3 x 3.2")	130 x 130 x 60mm (5.1 x 5.1 x 2.4")	130 x 130 x 60mm (5.1 x 5.1 x 2.4")
Drilling Dimensions	x	4 x M4 holes @ 145 x 123mm (5.7" x 4.8")	x	4 x M4 holes @ 145 x 123mm (5.7" x 4.8")	4 x M4 holes @ 113 x 113mm (4.4" x 4.4")	4 x M4 holes @ 113 x 113mm (4.4" x 4.4")



NOTE: Ensure operating voltage is correct for unit being installed.
DO NOT INPUT MAINS VOLTAGE INTO LOW VOLTAGE PSUs.

Power Supply Features

STANDARD PSU

- Adjustable photocell
- Adjustable power
- Telemetry input

PREMIUM PSU-PR

- Adjustable photocell
- Adjustable power
- Telemetry input
- Photocell following contact, volt free relay contact - normally open (day) to normally closed (night)
- 12V DC output @ 0.5A

PULSED PSU - PU

- Analogue version
- TTL version
- No photocell
- Adjustable power
- 12V DC output @ 0.5A
- Synchronised with camera

PREMIUM TIMER PSU-PRT

- Adjustable photocell
- Adjustable power
- Telemetry input
- Photocell following contact, volt free relay contact - normally open (day) to normally closed (night)
- 12V DC output @ 0.5A
- Timer function

Power Supply Diagrams (Not to scale)

INFRA-RED and WHITE-LIGHT RM/RL 50/25 Models

(Not to scale)

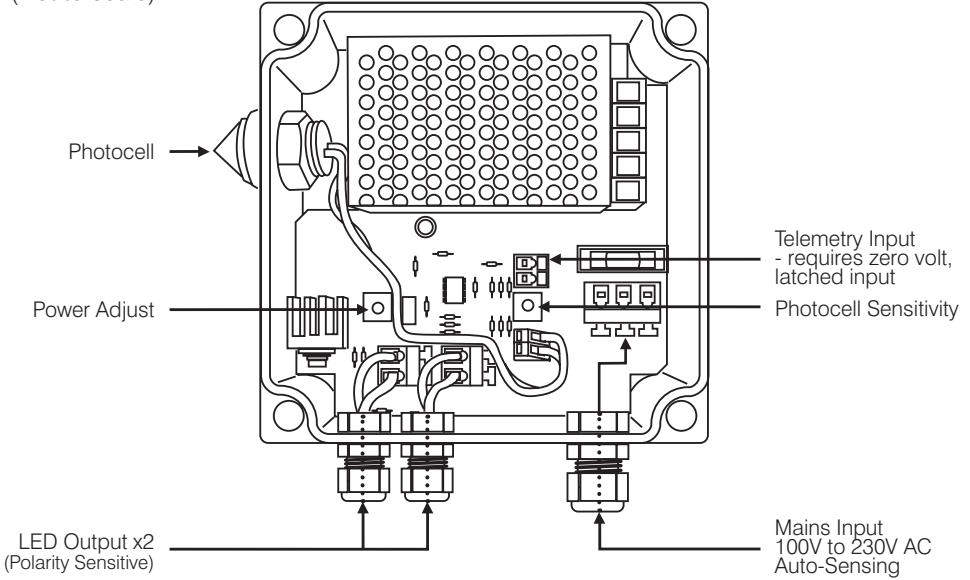

INFRA-RED and WHITE-LIGHT

RM/RL 200/100 Models (Model shown: RM/RL 100 Premium)

(Not to scale)

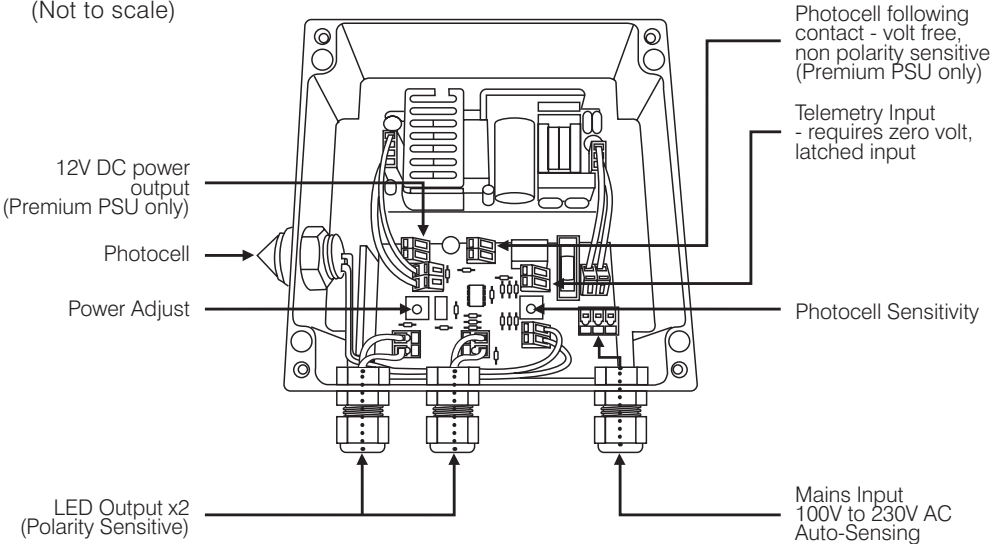

INFRA-RED and WHITE-LIGHT RM/RL 300/150 and Hybrid Models

(Final specification model dependant - model shown: RM/RL 300 Premium)

Note - Hybrid control boards will be labelled IR/WL

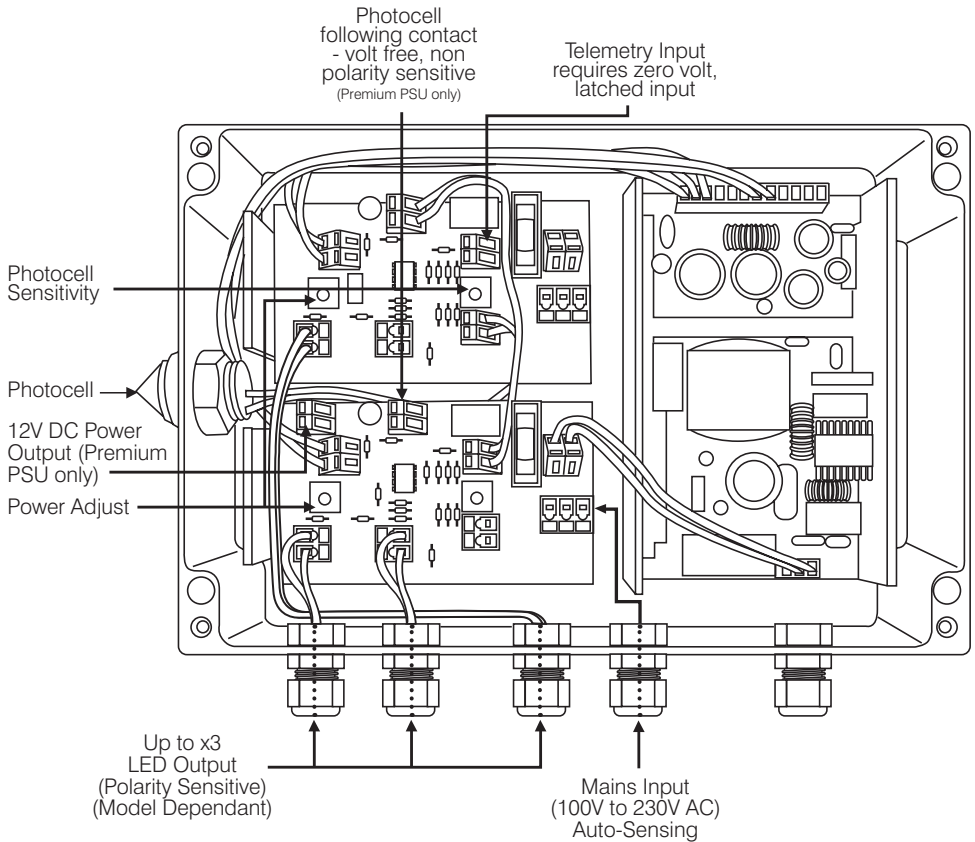

Trouble Shooting

Ensure all tests are undertaken by a qualified, trained engineer.
Ensure safe working practices are followed at all times

Step 1: Basics

- Check polarity of INFRA RED Lamp connection
red= +ve, black=-ve
- Check telemetry link is in
- Check photocell is working
- Check power setting pot fully clockwise
- Check mains input
- Check fuse intact

If OK...

Step 2: Lamp Test

Check voltage of lamp o/p approx 14V (8V for pulsed units)

Check current of lamp – see instructions for correct current setting

To check lamp current (this must be done while both LED panels are connected to the PSU) remove +ve LED from both lamp supply cables and connect multimeter set to 10A current in line with the lamp. [One lead of multimeter in common (COM), other lead into 10A socket of multimeter; set multimeter to 10A readings]. Refer to PSU Specifications for correct current settings, see pages 6-7.

Step 3: Set-up Camera, lens and illumination

Check alignment of lamp

Check camera lens – fully open at night & set correctly

Check model number to RayLED performance specification to ensure required distance is achievable

Step 4: Call RayLED for further assistance

Note down:

- Model and serial number of illuminator
- Camera make and model
- Lens make and model

If the RayLED lamp is still not delivering the required performance, please contact us for further assistance.

FUSION

illuminators installation guide

This installation guide provides instructions for installing the RAYMAX and RAYLUX FUSION series illuminators

Installation Steps

1. Mount Illuminator
2. Connect Illuminator to low voltage power supply
3. Input 12-24V DC/ 24V AC

Optional Set-up (if required)

4. Adjust Power to alter light intensity
5. Adjust Photocell sensitivity
6. Photocell following contact

RM/RL F 100 Setup

7. Telemetry input and photocell following contact

Set Up Steps

1. Position illuminator adjacent to camera and point towards scene
2. Adjust vertical and horizontal position of lamp to ensure full field of view illuminated
3. Tighten all fixings

Package Contents

1. Illuminator including mounting bracket
(RM/RL F 100 only, includes additional wiring loom)

Overview

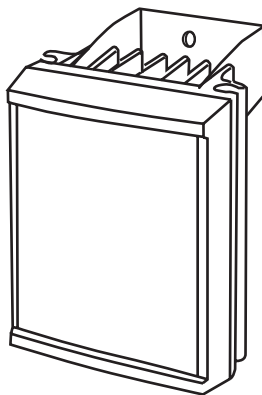

RAYMAX / RAYLUX
FUSION illuminator

GOLDEN RULES:

- Ensure operating voltage is correct for unit being installed (12-24V DC/ 24V AC)

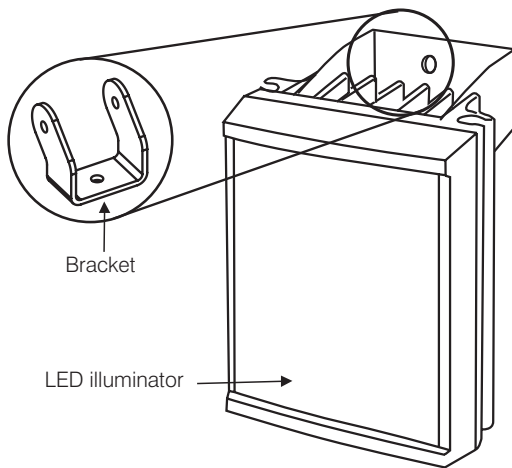

Bracket

LED illuminator

Back of Unit

'Command and Control' Technology™

RM/RL F 25 & 50

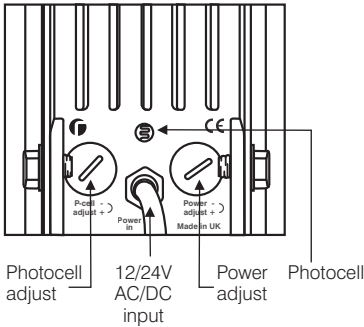

+ Photocell following contact

RM/RL F 100

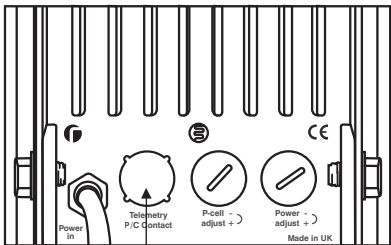

Telemetry Input & Photocell following contact

Cables

RM/RL F 25 & 50

1x four core cable

	DC	AC
Black wire	-	~
Red wire	+	~

Orange and Brown wires = Photocell following contact.
Volt free output. Non polarity sensitive.

RM/RL F 100

1x four core cable loom

	DC	AC
Black wire	-	~
Red wire	+	~

RM/RL F 100 is supplied with additional cable loom
White & Brown wires = Photocell following contact.
Volt free output. Non polarity sensitive.
Blue & Black wires = Telemetry connection.
Requires volt free input.

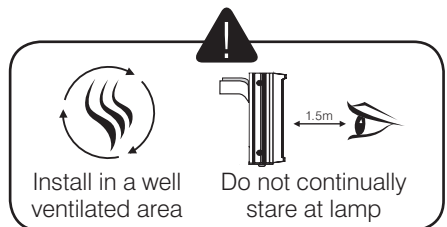

Install in a well ventilated area

Do not continually stare at lamp

Specifications subject to change without notice. Installation to be carried out by suitable trained and qualified personnel.

Installation

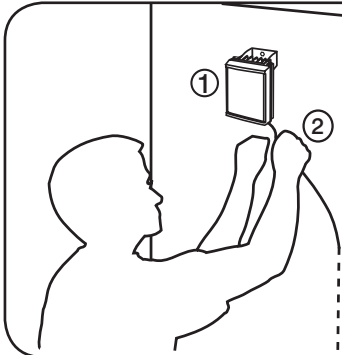

- 1 Mount illuminator
- 2 Connect Illuminator to low voltage power supply: Installers can extend or reduce lead length using appropriate cable and weather proof box
- 3 Input 12-24V DC/ 24V AC

Note: Red = **positive**
Black = **negative**

Optional Set-up (if required)

Note: Factory set to max. power

RM/RL F 25 & 50

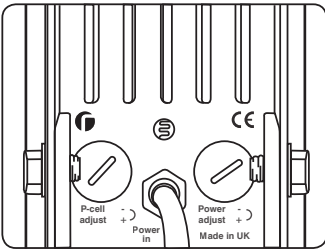

- 4 Adjust Power to alter light intensity. Remove the cover and turn the 'power adjust' to alter the intensity of the light level.

Clockwise=**increase**
Anticlockwise=**decrease**

- 5 Adjust Photocell sensitivity. Remove the cover and turn the 'photocell adjust' to alter photocell sensitivity to ambient lighting condition.

Clockwise=**more** sensitive
Anticlockwise=**less** sensitive

- 6 Photocell following contact, volt free relay contact - normally open (day) to normally closed (night).

RM/RL F 25 & 50 only
Orange and **brown** wires =
Photocell following contact

RM/RL F 100 only

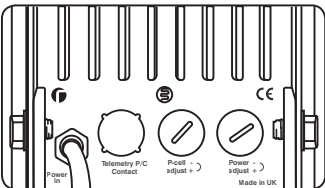

- 7 **RM/RL F 100 only:** Telemetry input and photocell following contact. Remove cap on telemetry and photocell following contact connector. Connect additional cable loom (see below).

RM/RL F 100 only
Blue and **black** wires =
telemetry connection for remote operation
White and **brown** wires =
photocell following contact connection

Set Up

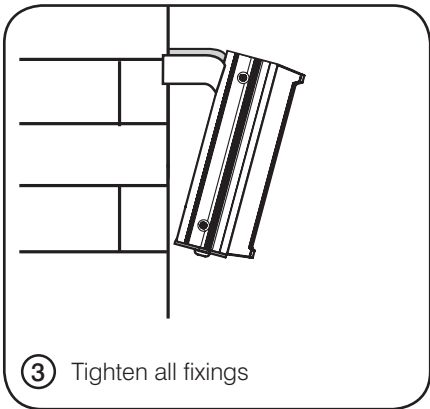
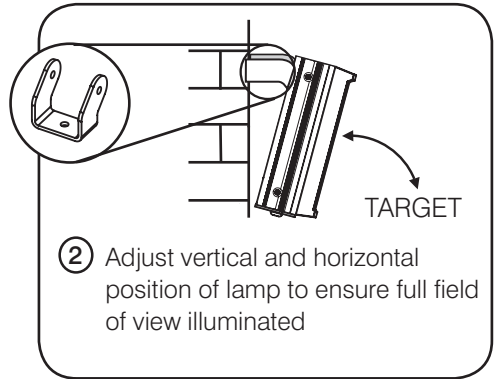
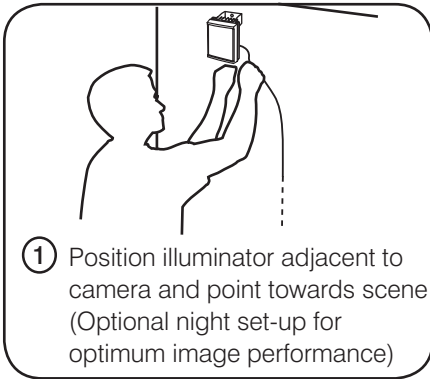

Match illumination to camera field of view

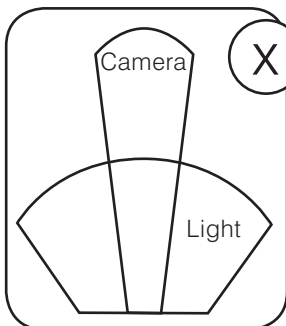

Reduces performance

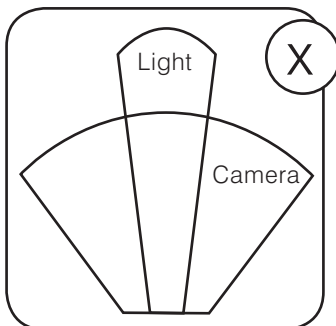

May cause hot spots

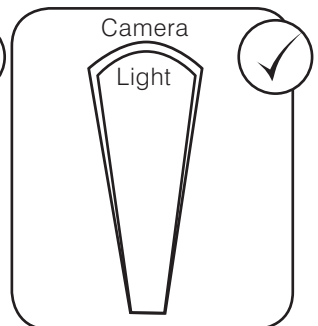

Best performance

Technical Drawings (Not to scale)

Standard Bracketry

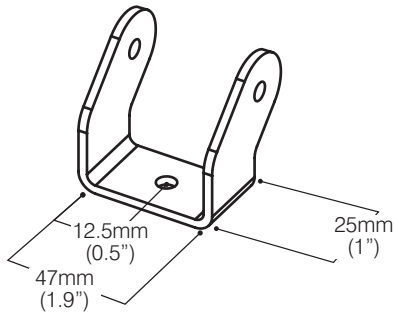

RM/RL F 25

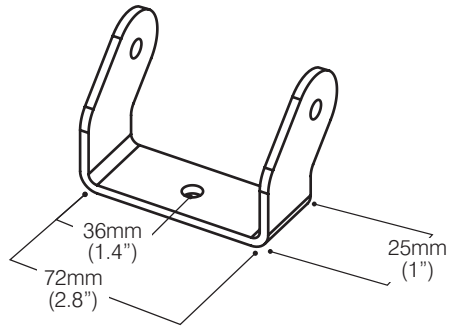

RM/RL F 50

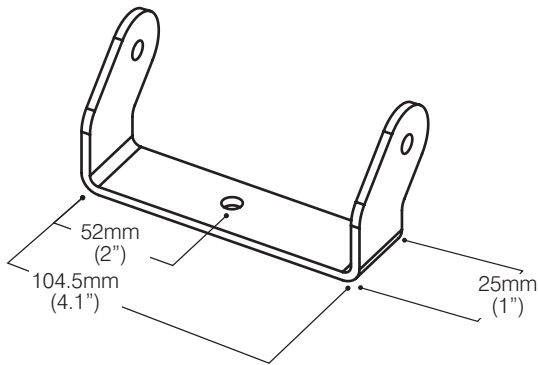

RM/RL F 100

Optional Bracketry

Wall Mount

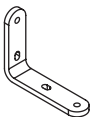

Ptz Mount

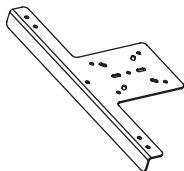

Dome Mount

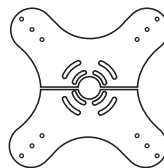

Pole Mount

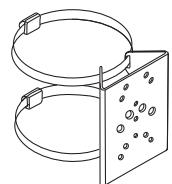

FUSION Specifications

INFRA-RED Series

	RM FUSION 100	RM FUSION 50	RM FUSION 25
Max. Distance Model dependent	150m	40m	20m
Consumption ~	35W max	25W max	12W max
Input	12-24V DC/ 24V AC	12-24V DC/ 24V AC	12-24V DC/ 24V AC
Current	2.6A @ 12V or 1.3A @ 24V	1.5A @ 12V or 0.75A @ 24V	1A @ 12V or 0.5A @ 24V
Weight	1.4kg	1.0kg	0.5kg
Environment	IP66	IP66	IP66
Dimensions L x W x D	180 x 135 x 65 mm (7 x 5.3 x 2.5")	135 x 100 x 63 mm (5.3 x 4 x 2.5")	75 x 100 x 54mm (3 x 4 x 2")

WHITE-LIGHT Series

	RL FUSION 100	RL FUSION 50	RL FUSION 25
Max. Distance Model dependent	100m	35m	17m
Consumption ~	35W max	25W max	12W max
Input	12-24V DC/ 24V AC	12-24V DC/ 24V AC	12-24V DC/ 24V AC
Current	2.6A @ 12V or 1.3A @ 24V	1.5A @ 12V or 0.75A @ 24V	1A @ 12V or 0.5A @ 24V
Weight	1.4kg	1.0kg	0.5kg
Environment	IP66	IP66	IP66
Dimensions L x W x D	180 x 135 x 65 mm (7 x 5.3 x 2.5")	135 x 100 x 63 mm (5.3 x 4 x 2.5")	75 x 100 x 54mm (3 x 4 x 2")

Integrated Command and Control™ Technology

RM/RL F 25/50

- Inbuilt photocell for automatic on/off operation
- Inbuilt power adjust
- Inbuilt photocell level adjust
- Photocell following contact

RM/RL F 100

- Inbuilt photocell for automatic on/off operation
- Inbuilt power adjust
- Inbuilt photocell level adjust
- Photocell following contact
- Telemetry input for remote operation

Trouble Shooting

Ensure all tests are undertaken by a qualified, trained engineer.
Ensure safe working practices are followed at all times.

Step 1: Basics

- Check polarity of Lamp connection
red= +ve, black=-ve
- Ensure power is 12-24V DC/ 24V AC
- Check photocell is working-cover photocell, light should turn on.
- Ensure power supply is suitably rated to product - check page 6 for specifications

If OK...

Step 2: Lamp Test

- Check current draw of lamp corresponds to specification on page 6
- Check current of lamp – see instructions for correct current setting

To check lamp current remove +ve (red) lead from power supply and connect multimeter (set to 10A) in line with the lamp. [One lead of multimeter in common (COM), other lead into 10A socket of multimeter; set multimeter to read Amps]. Refer to PSU Specifications for correct current settings, see page 6.

Step 3: Set-up Camera, lens and illumination

- Check alignment of lamp
- Check camera lens – fully open at night & set correctly
- Check model number to Rayled performance specification to ensure required distance is achievable

Step 4: Call Rayled for further assistance

Note down:

- Model and serial number of illuminator
- Camera make and model
- Lens make and model

If the Rayled lamp is still not delivering the required performance, please contact us for further assistance.

