

VARIO2

Quick Start

Safety Information:



White Light and IR Variants (850nm & 940nm)

Caution – Risk Group 2. Avoid Exposure / use protection.
See Safety Information in FULL Instruction Guide for details.

Box Contents:

VARIO2 Illuminator with 35° ILS fitted, spare 60° beam angle ILS, User Guide (ILS: Interchangeable Lens System)

Optional Accessories: Remote Controller for additional programming, 80° beam angle ILS, 120° beam angle ILS, Bracketry

Factory Default Set-Up:

35° Beam Angle ILS, Max 100% Power

Telemetry Input – closed, Photocell sensitivity – MID

Status LEDs – ON, No PIN Set

Unit will change from Programming Mode to Operating Mode after 7 Days (or 30 minutes after last press of manual buttons)

VARIO2 Specifications Table:

	i16	w16	i8	w8	i6	i4	w4	i2	w2
Consumption	100W max	84W max	46W max	42W max	25W max	13W max	24W max	10W max	11W max
Input	24V AC/DC		12/24V AC/DC		12/24V AC/DC			12/24V AC/DC	
Weight	3.1kg (6.8lbs)		1.65kg (3.61lbs)		950g (2.1lbs)			600g (1.3lbs)	
Number of LED's	48		24		12	9	12	6	6
Environment	IP66		IP66		IP66			IP66	
Dimensions	180 x 277 x 75mm 7" x 11" x 2.9"		135 x 180 x 68mm (5" x 7" x 3")		100 x 135 x 66mm 4" x 5" x 2.5"			75 x 100 x 64mm 3" x 4" x 2.5"	
Cable Length	2.5m	2.5m	2.5m	2.5m	2.5m	2.5m	2.5m	2.5m	2.5m

Wiring:

1. Mount Illuminator
2. Connect Illuminator to low voltage input 12-24V AC/DC
IMPORTANT: For Vario 16 variants : **24V only** AC/DC
3. Complete configuration, wiring and final set-up using manual push buttons on the illuminator or VARIO Remote Controller (VRC) - VRC is an optional accessory

Black Wire = Negative (+ve)

Red Wire = Positive (-ve)

White & Yellow wires = Photocell following contact, Volt free output, Non polarity sensitive

Orange and Purple Wires = Telemetry input Volt free / dry contact or TTL input

Lens Selection:

VARIO is factory set and delivered with a 35° beam width angle.

To alter to 10°, simply remove interchangeable lens (ILS).

To alter to 60°, replace with other ILS lens supplied.

Other angle ILS lenses are available to order: 80° and 120°.

Please handle ILS lenses with care – and do not touch optical film.

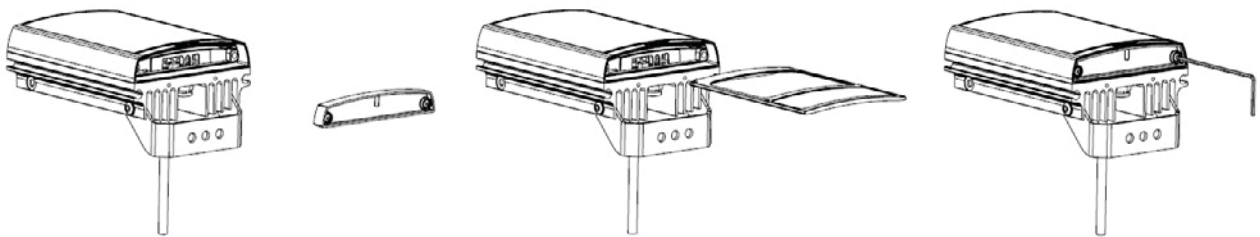

Use 2.5mm Allen/hex key. Re-attach base plate securely ensuring gasket is correctly located.

Important Note : Ensure base plate is securely located, the gasket is correctly located and the screws correctly fastened to ensure and maintain IP66 rating of the product

Manual Button Operation

Buttons are accessed by removing the base plate at the bottom of the unit. The number of button pushes indicated below are based on the user starting with the illuminator in either programming or operating mode.

Action Required	Step1 : LHS Button	LHS LED	Step 2 : RHS Button	RHS LED	Comment
Power Adjust	1 x Push	Solid Red	Each Push cycles through power levels	Green flashes indicate level. High power (5 flashes) to Low power (1 flash)	
Photocell Adjust	2 x Push	Solid Green	Each Push cycles through photocell levels	Green flashes indicate 3 sensitivity settings: Low: 1 Flash Med: 2 Flashes High: 3 Flashes Solid Red for Photocell disabled.	
Status Indicator LEDS On / Off	3 x Push	Solid Amber	Each Push cycles between On and Off	On – Green Off - Red	
Factory Re-set (Does not Re-set PIN)	1 x Long Push (4 Seconds)	Flashing Red –	Push and Hold until both LEDs flash Amber	Solid Red – After 4s both LEDs Flashing Amber	Reverts to Programming Mode unless a PIN is present. If a PIN is present reverts to original mode before re-set
Disable Remote Control	1 x Long Push (4s), then 1 x short Push	Flashing Green	Push to cycle Disable / Enable	Disable – Red Enable - Green	Reverts to the Mode requested unless a PIN is present. If a PIN is present and you are in Operating Mode you cannot change to Programming Mode

Action Required	Step1 : LHS Button	LHS LED	Step 2 : RHS Button	RHS LED	Comment
Disable / Enable Manual Buttons	1 x Long Push (4s), then 2 x short Push	Flashing Amber	Push to cycle Disable / Enable	Disable – Red Enable - Green	Buttons will be Disabled 30 minutes after this selection is made – This is to allow the user to re-enable manual buttons if required
Full Re-set (including PIN re-set)	Keep both buttons depressed during power up – LEDs will both flash Amber	Flashing Amber then solid green after button release	Keep both buttons depressed during power up – LEDs will both flash Amber	Flashing Amber then Flashing Amber after button release	Illuminator will revert to Programming Mode, Full factory default including No PIN

The illuminator has two modes;

- (1) Programming Mode when the remote control can be used and
 - (2) Operating Mode when most of the remote control functions are disabled.
- The only remote control functions that can be used in Operating mode are; Enable/Disable Status LEDs, Disable Manual Buttons and PIN entry.

Manual Buttons are always available in programming mode or if they have been disabled, they can be enabled in programming mode.

Manual Buttons are available in operating mode, provided they have not already been disabled.

The number of button pushes indicated above are based on the user starting with the illuminator in either programming or operating mode.

If no buttons are pressed within 2 minutes then the illuminator will automatically default back into the previous mode it was in – programming or operating mode.

VARIO Remote Controller (VRC) Optional Accessory

Full instructions provided with VRC when supplied

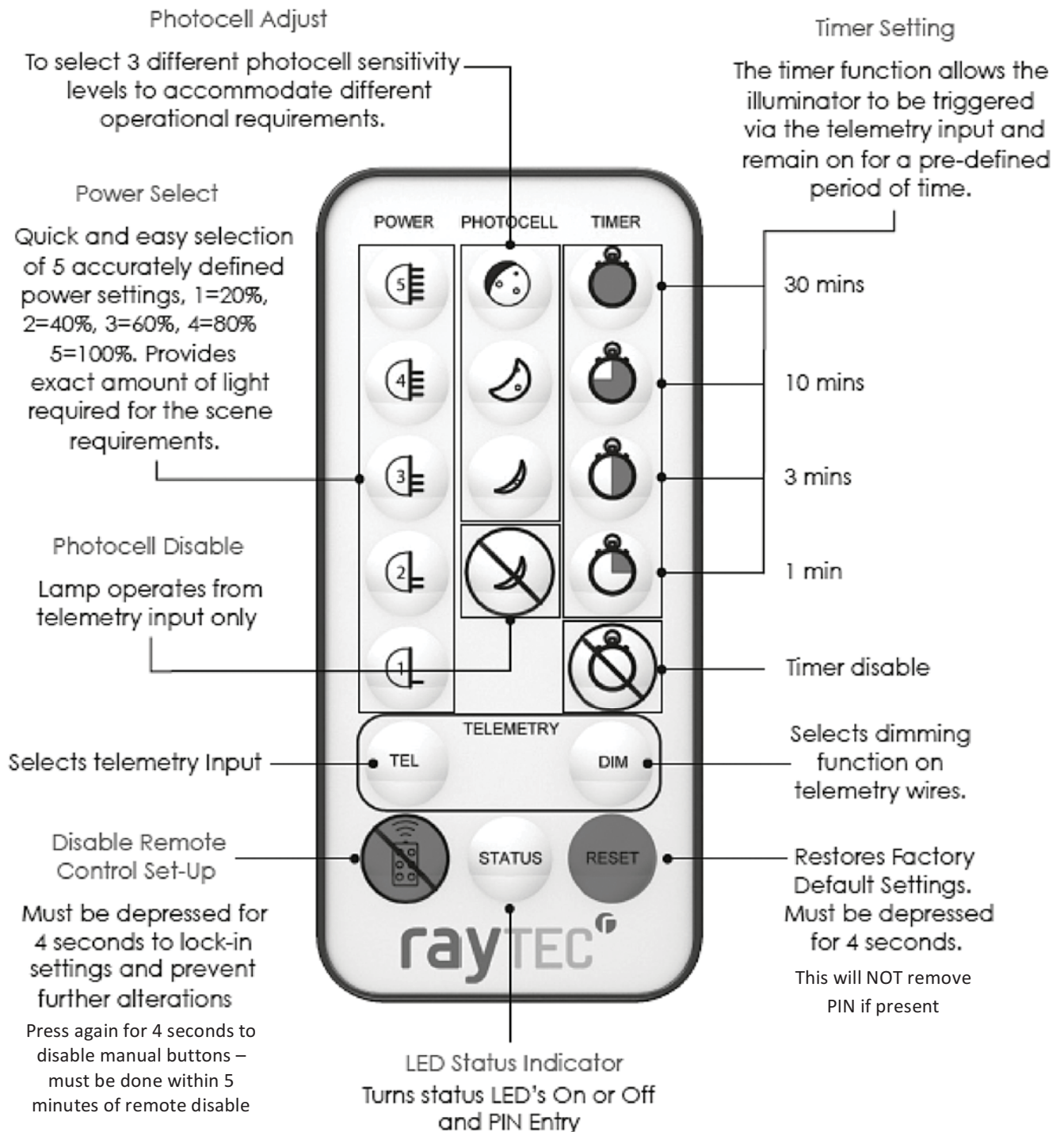

For extra security VARIO2 allows a PIN (Personal Identification Number) to be set. There are five buttons / characters on the remote that can be used for this purpose : Power 5, Power 1, Min Photocell (Smallest moon), Max Timer (Full Red Circle) & Timer Disable (Timer Circle image with a line through) . Note – invalid characters will not be recognised.

Remote Control Operation

PIN set and Manual Button Disable / Enable

Action Required	Available Mode	Step1	Step 2	LHS LED	RHS LED	Comment
Disable Remote	Programming Mode	Press <Disable Remote Control> button on VRC for 4 seconds	N/A	Solid Green	Flashing Amber to Solid Amber to Off	Illuminator will go to Operating Mode. RHS LED turns Off when in Operating Mode.
Disable Manual Buttons	Operating Mode	Press <Disable Remote Control> button on VRC for 4 seconds	N/A	Solid Green – After 4 seconds Flashing Red (Returns to Solid Green after button release)	Off to Solid Amber, then after 4 seconds Flashing Red (Returns to Solid Green after button release)	Must be done within 5 minutes of Disabling remote (as above) Change will take effect after 30 minutes
Create or Change PIN	Programming Mode	Press <Status Button> for 4 seconds	Enter valid PIN characters x 4	Green to Intermittent Flashing Red / Green	Solid Amber to Flashing Red Flash qty counts down the No. of characters required.	After PIN created Illuminator goes to Programming Mode (Standard LED indication)
Enter existing PIN	Operating Mode	Press <Status Button> for 4 seconds	Enter valid PIN character x 4	Green – Intermittent Flashing Red / Green	Solid Amber to Flashing Green Flash qty counts down the No. of characters required	If invalid PIN entered both LEDs flash red and unit will stay in Operating Mode
Delete PIN	Programming Mode	Press <Status Button> for 4 seconds	Press <Re-Set> button 4 times	Green – Intermittent Flashing Red / Green	Solid Amber to Flashing Red Flash qty counts down the No. of characters required	After PIN deleted Illuminator goes to Programming Mode (Standard LED indication)

For full PIN function detail (inc valid PIN characters) – see FULL instruction guide

LED Status Indicators:

Programming Mode and Operating Mode

On first power up (Factory Default) the illuminator automatically enters Programming Mode. It will then time out automatically after 7 Days to Operating Mode unless the user actively disables the remote control or uses the manual buttons in which case Operating Mode will start 30 minutes after the last manual button press. The LED Indicators feedback the mode you are in. (They are also used for PIN or Manual Button Control Modes – please see tables / FULL Instruction Manual)

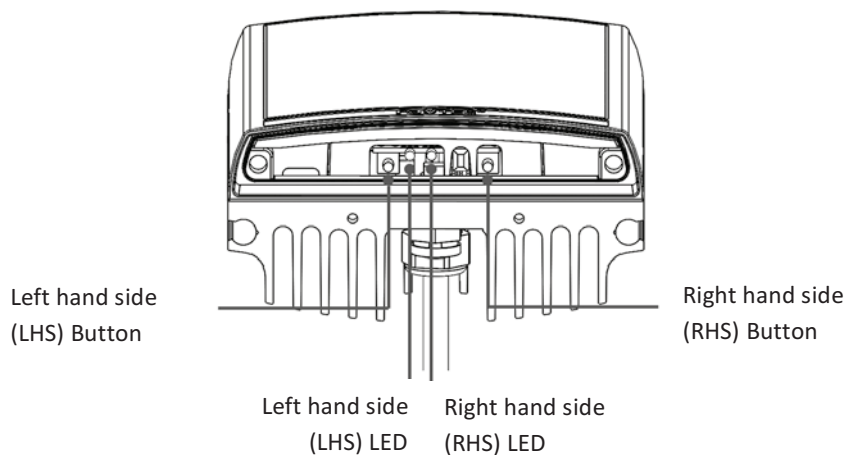

During Programming Mode and Operating Mode the two LED's indicate the following status :

- LHS SOLID GREEN: Power Applied
- LHS FLASHING GREEN: Remote control IR received problem
- RHS FLASHING AMBER: Indicates unit is in programming mode (Programming Mode Only)
- RHS SOLID AMBER: Indicates that a valid command is being received (Programming Mode Only)
- LHS FLASHING RED: Voltage supply problem detected
- LHS SOLID RED: Illuminator LED fault detected

All functions of the remote control and buttons are available in Programming Mode.

The only function of the Remote Control available during Operating Mode is LED Status Indicators Enable/Disable, entering a PIN or disabling manual buttons (if done at the same time as disabling the remote – see FULL Instruction Manual)

RESET:

Settings Re-set : Pressing and holding the RESET BUTTON on the remote control or using the manual buttons to complete a RESET will restore the factory settings to the illuminator. Note : It will not remove a PIN if one is present.

Full Re-set : Re-cycling the power whilst pressing both manual buttons will restore factory settings and remove a PIN if one is present.

Both indicator LEDs flash amber for both above re-sets when complete.

VARIO2 Quick Troubleshoot:

Ensure all tests are undertaken by a qualified, trained engineer. Ensure safe working practices are followed at all times.

- Check polarity of illuminator connection red=+ve, black=-ve
- Ensure power is 12-24V AC or DC (For Vario 16 variants : **24V only** AC or DC)
- Ensure telemetry wires are shorted out or valid telemetry input (zero volt or TTL) is applied and correctly wired
- Check photocell is working. Cover photocell fully, light should turn on if valid telemetry input. It is sometimes difficult to see Infra-Red illuminators working in high brightness conditions.
- Ensure power supply is suitably rated to product - check page 1 for specifications
- If longer cables used, ensure sufficient voltage is provided to allow for drops across the cable

For in-depth Troubleshoot, see Full Instructions, or contact RayLED.



Main Office:

T: +33 4 58 00 15 74

F: +33 9 55 70 03 53

E-mail: sales@rayled.com

www.rayled.com

Full Installation Guide



VARIO2 w16

VARIO2 i16

VARIO2 w8

VARIO2 i8

VARIO2 i6

VARIO2 w4

VARIO2 i4

VARIO2 w2

VARIO2 i2

Contents :

Page 2	Box Contents and Safety Information
Page 3	Short Guide and Factory Defaults
Page 6	LED Status Indicators – Feedback System
Page 8	VARIO Remote Controller (VRC)
Page 10	PIN Function Detail
Page 12	Manual Control Buttons
Page 17	Disabling Manual Buttons
Page 18	Power Up Functionality ; Re-Set Options
Page 19	Standard Bracketry
Page 20	Specifications Table
Page 21	Troubleshooting

Box Contents :

VARIO2 Illuminator , spare 60° beam angles ILS
(ILS: Interchangeable Lens System)
Accessories (Optional) :VARIO Remote Control for additional Programming;
80° beam and 120° beam angle ILS; Bracketry

VARIO2 Enhancements

- Increased Distance
- Default time for illuminator to go into Operating Mode reduced
- PIN function for enhanced security
- Manual Control added – Push Buttons Accessible on the illuminator
- Improved RESET Options
- The 3 single colour feedback LED's have been replaced with 2 tri-colour LED's

Safety Information



Eye Safety : IR Variants (850nm and 940nm)

Caution – IR emitted from this product EN62471 Risk Group 2
Do not stare at the lamp. Avoid exposure or use appropriate shielding / eye protection. Risk Group 2 for cornea / lens infrared hazard. For VAR-i2, VAR-i4, VAR-i6 and VAR-i8 variants hazard distance is 1500mm. For VAR-i16 hazard distance is 1840mm. Max IR EHV (Exposure Hazard Value) : 69% of Risk Group 2 Limit at 200mm from the lamp.

Eye Safety : White Light Variants

Caution – EN62471 Risk Group 2 Classification - Possible hazardous optical radiation emitted from this product. May be harmful to eyes, do not stare at the lamp. For VAR-w2, VAR-w4, VAR-w8 Hazard distance is 1500mm. For VAR-w16 hazard distance is 1840mm. Max WL EHV (Exposure Hazard Value) : 68% of Risk Group 2 Limit at 200mm from the lamp.

The Illuminator is Class III for insulation

Illuminators are suitable for use Outdoors and Indoors

Installation Steps:

1. VARIO2 is factory set and delivered with a 35° beam width.
To alter to 10°, simply remove interchangeable lens (ILS). See page 4 for detailed instructions
To alter to 60°, replace with other ILS lens supplied.
2. Mount Illuminator
3. Connect Illuminator to low voltage input 12-24V AC/DC (For Vario 16 variants : **24V AC or DC only**)
- 4-6. Complete configuration, wiring and final set-up using manual push buttons on the illuminator or VARIO Remote Controller (VRC)
- VRC is an optional accessory

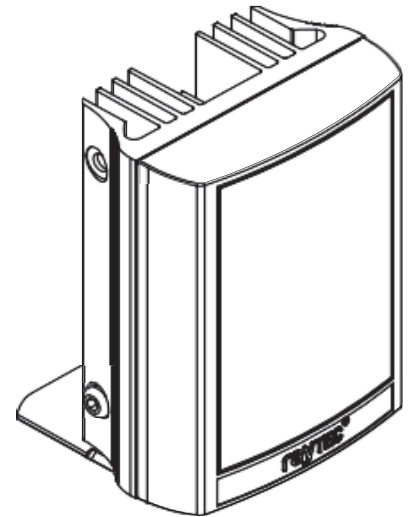

Wiring – six core cable

	DC	AC
Black Wire	-	~
Red Wire	+	~

White & Yellow wires =

Photocell following contact,
Volt free output, Non polarity sensitive

Orange and Purple Wires =

Telemetry input Volt free / dry contact or
TTL input (see Page 5 and 6 for more detail)

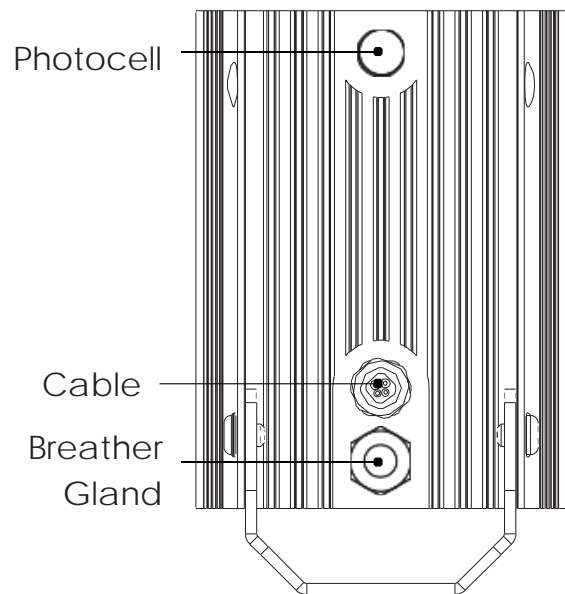

The external cable cannot be replaced. If it is damaged and the customer is unable to shorten and re-use the cable, the illuminator must not be powered.

Factory Default Set-Up:

35° Beam Angle ; Max 100% Power

Telemetry Input – closed ; Photocell sensitivity – MID

Status LEDs – ON ; No PIN Set ; Manual Button Control Enabled

Programming function will auto-disable after 7 Days

VARIO2 Complete Set up and Installation

Step 1. Select different beam angle – if required

VARIO is factory set and delivered with a 35° beam width angle.

To alter to 10°, simply remove interchangeable lens (ILS).

To alter to 60°, replace with other ILS lens supplied.

Other angle ILS lenses are available to order: 80° and 120°.

All ILS lenses will be clearly marked with the angle which they will produce when inserted into VARIO2.

Please handle ILS lenses with care – and do not touch optical film.

Only 1 ILS lens can be inserted into the product at anytime. The product cannot accommodate multiple ILS lenses at the same time.

We would recommend that power is turned off when replacing ILS lenses.



Remove base plate from VARIO2 unit using 2.5mm allen/hex key. Insert required ILS lens and re-attach base plate securely ensuring gasket is correctly located.

Important Note : Ensure base plate is securely located, the gasket is correctly located and the screws correctly fastened to ensure and maintain IP66 rating of the product

Step 2. Mounting Illuminator

VARIO2 is delivered as standard with bracket at the bottom of the unit. This can be moved to the top of the unit if required. See page 18 for optional brackets

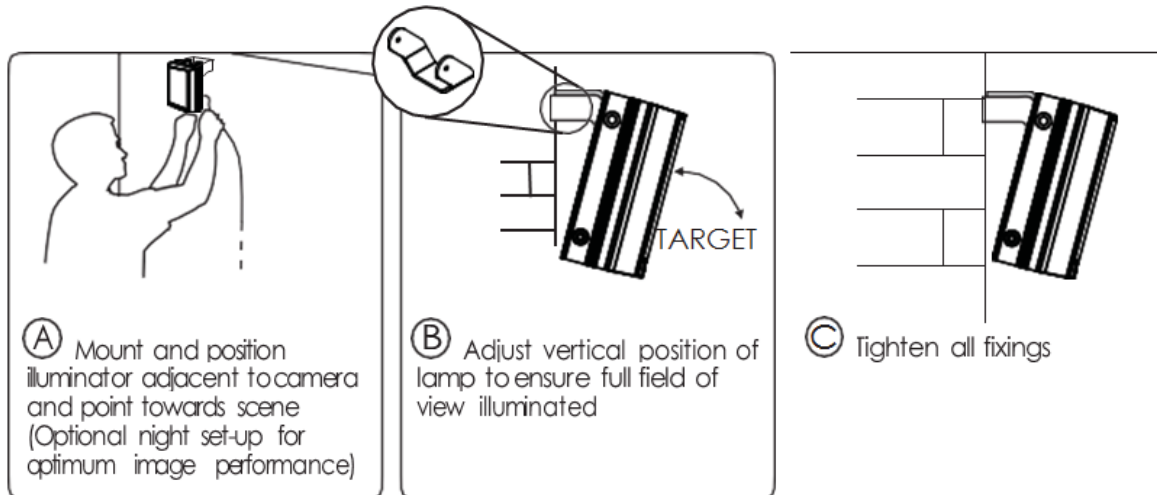

Step 3. Connect to low voltage power supply and input 12-24 AC/DC (24 AC/DC only for Vario 16 variants)

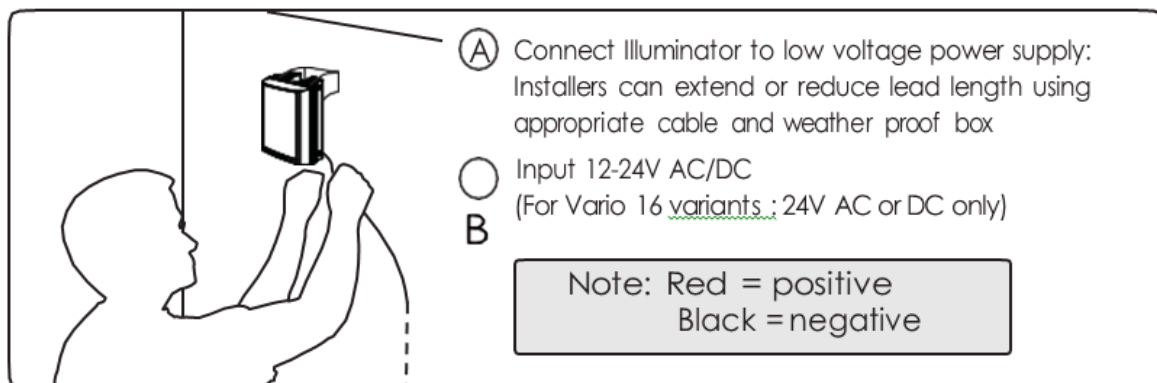

Step 4. Telemetry Input (Orange & Purple)

As default the telemetry input will be wired together so that the unit turns on/off automatically via the photocell. If required to be activated by PIR or alarm system, connect to appropriate, volt-free or TTL input. Volt free input/dry contact: Non polarity sensitive, short circuit = light on
TTL input: Orange = TTL +ve, Purple = TTL -ve (GND) 0V = Light on, 3V = Light off

Step 5. Photocell following output (White & Yellow)

Volt free output - normally open (day) to normally closed (night).
Connect direct to camera if required to control switchover of day/night cameras.

Step 6. Programme using optional VARIO Remote Control (VRC) or the manual control buttons.

Step 7. Set PIN (If Required) (Can only be done with the optional VARIO Remote Control(VRC))

LED Status Indicators- Feedback system :

There are two tri-coloured LEDs visible on the base of the VARIO2 illuminator. The two LEDs provide important operating and status information.

The LED Indicators also give feedback if you are using the Remote, PIN Function or Manual Control Modes – Please see Pages 10 to 17 for detail on the LED status indicator feedback for these functions

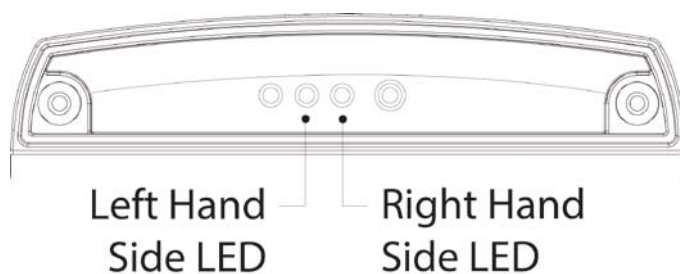

Programming Mode and Operating Mode

On powering up the illuminator, it automatically enters programming mode to allow the user to adjust set-up and operation. The programming mode automatically times out after 7 Days or until the user actively disables the remote control or the unit times out 30 minutes after any press of the manual buttons on the illuminator.

During Programming Mode and Operating Mode the two LED's indicate the following status :

LHS SOLID GREEN: Power Applied

LHS FLASHING GREEN: Remote control IR receiver problem (Max VRC distance is 8m (26ft)

RHS FLASHING AMBER: Indicates unit is in programming mode (Programming Mode Only)

RHS SOLID AMBER: Indicates that a valid command is being received from the remote (Programming Mode Only)

LHS FLASHING RED: Voltage supply problem detected

LHS SOLID RED: Illuminator fault detected

All functions of the remote control and buttons are available in Programming Mode.

The only function of the Remote Control available during Operating Mode is LED Status Indicators Enable/Disable, entering a PIN or disabling manual buttons (if done at the same time as disabling the remote – see P.8)

Factory Default: On initial power-up, Programming Mode.

VARIO Remote Controller (VRC) :

Optional Accessory

Full instructions provided with VRC when supplied

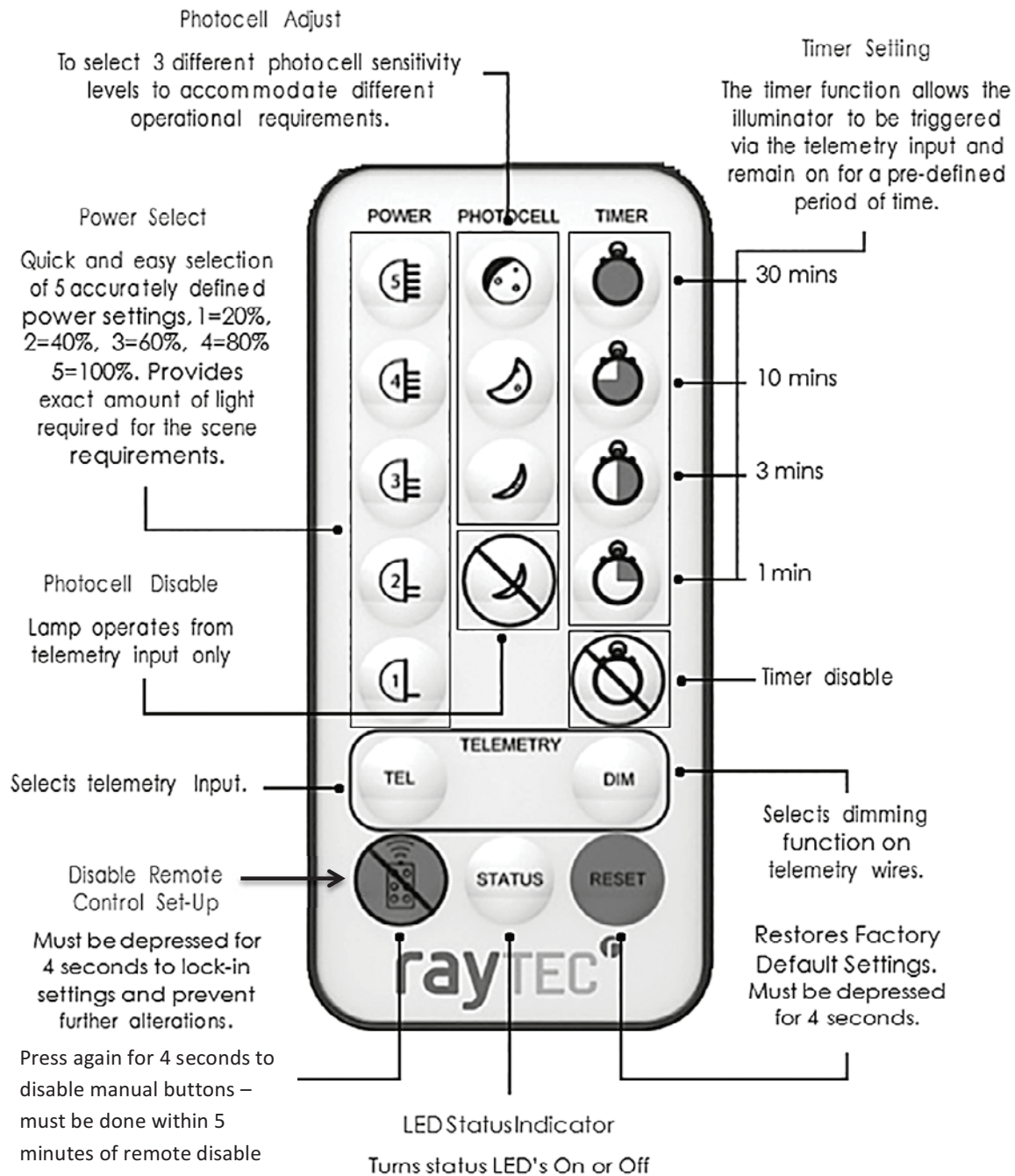

Note : Reset button will not remove a PIN if one is present

Note : Unless detailed as part of the functionality, if an invalid or blocked command is attempted, both LEDs will flash RED

Extra VRC Functionality :

- PIN Function

For extra security VARIO2 allows a PIN (Personal Identification Number) to be set for each lamp

The PIN is set by using the Vario Remote Control (VRC). There are five buttons / characters on the remote that can be used for this purpose.

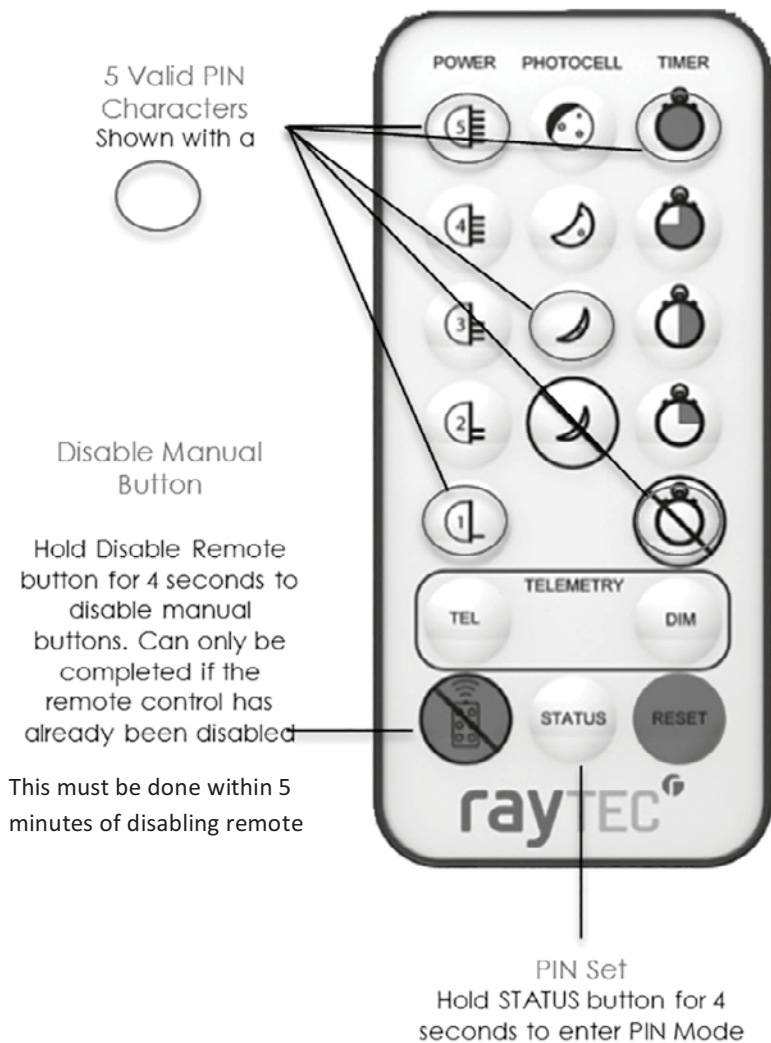

Note : Unless detailed as part of the functionality, if an invalid or blocked command is attempted, both LEDs will flash RED

PIN Function Detail :

The PIN is set by using the Vario Remote Control (VRC). There are five buttons / characters on the remote that can be used for this purpose. They are Power 5, Power 1, Min Photocell (Smallest moon), Max Timer (Full Red Circle) & Timer Disable (Timer Circle image with a line through) .
Note – invalid characters will not be recognised.

To create a PIN, press STATUS BUTTON for 4 seconds. LHS LED will flash RED/GREEN. This indication will always show that you are in PIN mode. RHS LED FLASHING RED shows there you are in PIN set mode. The number of flashes indicates how many characters are required to complete the PIN entry. There are four characters to be entered to successfully set up a PIN.

As you enter the characters, the number of flashes will decrease until all characters are entered. Note, illegal characters will not be recognised and will not reduce the number of flashes. When the PIN is set the illuminator will revert to Programming Mode.

When a PIN is Set :

Using the remote you can access the illuminator settings from operating mode by entering the PIN.

You cannot access Programming Mode by power re-cycling only.

In operating mode, if you want to go back into programming mode simply enter your PIN. To do this, press STATUS BUTTON for 4 seconds. LHS LED will flash RED/GREEN to show you are in PIN mode. RHS LED FLASHING GREEN shows that a PIN has been previously set. As you input the four correct characters the number of flashes will reduce and you will be returned to programming mode.

If legal characters but not the correct sequence of characters is entered the number of flashes will still reduce and after 4 characters have been entered an error will be shown by both LED`s flashing RED.

If an illegal character is used when entering a pin, it will be ignored and the PIN character count will not reduce.

To delete an existing PIN you first need to be in Programming Mode by entering your PIN. Once in Programming Mode, press STATUS BUTTON for 4 seconds to go into PIN set mode. LHS LED will flash RED / GREEN and RHS LED FLASHING RED. Instead of entering one of the known legal characters press the RESET BUTTON four times. The illuminator will return to programming mode. Note – if you delete the PIN and the illuminator times out into operating mode, you will not be able to go back to programming mode without recycling the power.

*Note - If you forget your pin and need to make adjustments to the illuminator you need to do full Re-set. This requires power recycling whilst pressing the two manual control buttons at the same time. This will restore factory default settings AND remove the previously programmed PIN. Both LEDs will flash AMBER to signify that the process has been completed.

*Note – If you need to check if a PIN is set up, in Operating Mode hold the status button down for 4 seconds and both LEDs flash RED, this means there is no PIN present.

Manual Control – Buttons :

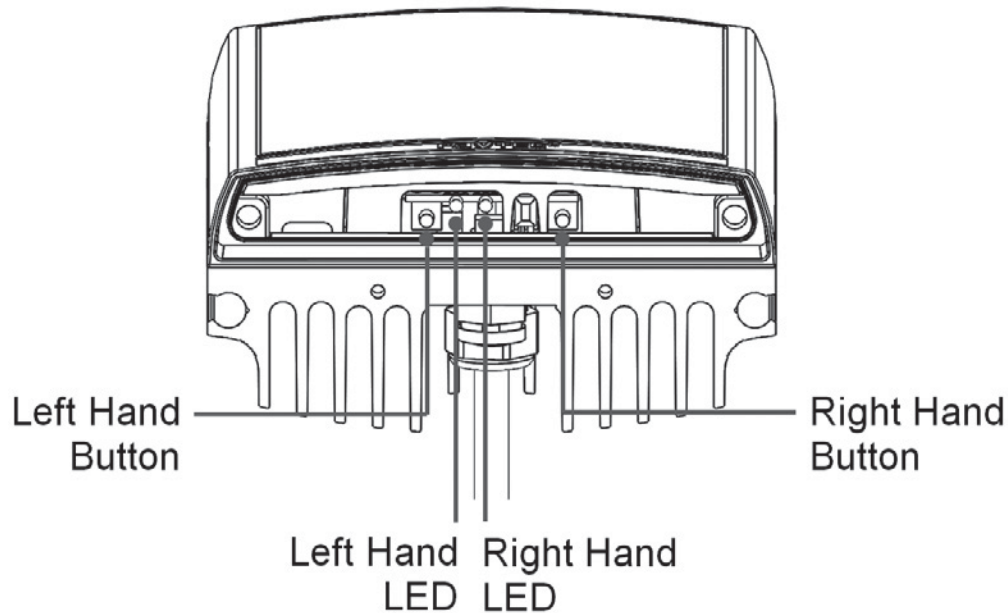

The two manual control buttons gives a wide selection of user control :

1. Power Control – 100%, 80%, 60%, 40%, 20% of maximum. (Factory Default is 100%)
2. Photocell Control – 3 levels, 25 Lux on, 50 Lux off, 10 Lux on 30 Lux off, 5 Lux on 15 Lux off and photocell disable.
3. Turn LED indicators on & off
4. Illuminator Reset Options
5. Disable Remote Control and enter Operating Mode or Enable Remote Control and enter Programming Mode
6. Button Enable & Disable

Manual buttons can be accessed by removing the base cover of the illuminator

The buttons are active in both programming mode and operating mode regardless of whether a PIN is present or not unless you have previously disabled the manual buttons

As soon as manual button mode is entered by pressing the Left Hand Button, the standard LED indicators will be disabled and will indicate a new set of information, Standard LED indicators are enabled after exiting manual button modes.

Note : Unless detailed as part of the functionality, if an invalid or blocked button push is attempted, both LEDs will flash Red

Mode Selection by using LHS Button :

A momentary press of LHS button turn LHS LED solid RED and enters the user into the **Illuminator Settings Modes**.

In these modes you can change the following settings :

- Power Level
- Photocell sensitivity
- Indicator LED status (On or Off)

A continuous 4 second press of the LHS button turns LHS LED flashing RED and enters the user into the **Illuminator Security Modes**.

In these modes you can change the following Security/Configurations :

- Illuminator Re-set
- Disable Remote Control and enter Operating Mode or Enable Remote Control and enter Programming Mode
- Manual Button Enable / Disable

*Note – If the status indicator LEDs are disabled and you use the manual buttons the indicator LEDs will still illuminate accordingly

Manual Setting / Level Indication using RHS Button :

The RHS BUTTON will only have an effect if you have selected a mode using LHS Button – pressing RHS Button without previously pressing LHS Button will have no effect on the Illuminator operation – it is used to control the setting for the mode chosen by LHS Button

When you select a mode using LHS BUTTON, the LHS LED will confirm which mode you are in and RHS LED will show the current setting / level of that mode for the Illuminator.

Sequential presses of RHS BUTTON will take you through the available options to get to the required setting you want within that mode. The Illuminator will stay at this setting / level providing you do not push the RHS BUTTON again. Once you have reached the required setting as shown in the following text, EITHER press the LHS BUTTON to cycle through the modes until LHS LED extinguishes showing that you are at the end of the mode loop OR you can also wait 2 minutes for the illuminator to time out and the value shown by RHS LED will be stored into the illuminator memory.

The settings programmed will be retained on power recycling unless a reset has been performed, in which case the factory defaults will be applied.

Illuminator Settings Mode Detail :

Enter this mode by a momentary press of LHS button to turn LHS LED solid RED.

Pressing the LHS button again will turn the LED solid GREEN and pressing a third time will turn the LED solid AMBER. Each of these colours indicates which setting mode you are in.

A further momentary press of LHS Button will exit from the mode entry, both LEDs will go out for 1 second and then return to the standard indication of either operating mode or programming mode (depending on which mode the Illuminator was in previously before selecting manual controls.

The following modes are available :

Power Level Mode (LHS LED : Solid RED)

RHS LED :

20% Power Setting: 1 Flash GREEN

40% Power Setting: 2 Flashes GREEN

60% Power Setting: 3 Flashes GREEN

80% Power Setting: 4 Flashes GREEN

100% Power Setting: 5 Flashes GREEN

Photocell Level Mode (LHS LED : Solid GREEN)

RHS LED:

Low sensitivity: 1 Flash GREEN

Medium Sensitivity: 2 Flashes GREEN

High Sensitivity: 3 Flashes GREEN

Disabled photocell: Solid RED

Enable / Disable Status Indicator LEDs Mode (LHS LED: Solid AMBER)

RHS LED:

Enable LEDs: Solid GREEN

Disable LEDs: Solid RED

NOTE – If no buttons are pressed within 2 minutes the Illuminator times out and returns to the previous mode it was in – either operating or programming mode.

Illuminator Security Modes Detail :

Enter this mode by a long 4 second press of LHS button to turn LHS LED Flashing RED.

Pressing the LHS button again momentarily will turn the LHS LED Flashing GREEN and pressing a third time momentarily will turn the LHS LED Flashing AMBER. Each of these colours indicates which setting mode you are in.

A further momentary press of LHS Button will exit from the mode entry, both LEDs will go blank for 1 second and then return to the standard indication of either operating mode or programming mode (depending on which mode the illuminator was in previously before selecting manual controls)

The following modes are available :

Illuminator Reset Mode (LHS LED : Flashing RED)

RHS LED: Solid RED

Keep RHS BUTTON depressed for 4 seconds. RHS LED stays solid RED and then after 4 seconds both LEDs flash AMBER to show the illuminator has been reset. This operation is equivalent to the factory reset button on the remote control. It will not re-set a PIN if one is present.

Remote Control Disable and Enter Operating Mode or Remote Control Enable and enter Programming Mode (LHS LED : Flashing GREEN)

RHS LED:

Enable Remote: Solid GREEN

Disable Remote: Solid RED

Note : If there is a PIN present and the Illuminator is in Operating mode you cannot enable the Remote Control and enter Programming Mode

Enable & Disable of Manual Control Buttons (LED A : Flashing AMBER)

RHS LED:

Enable Manual Button Control – Solid GREEN

Disable Manual Button Control – Solid RED

Note : If the illuminator is in Operating Mode and the buttons are currently disabled, you cannot re-enable.

NOTE – If no buttons are pressed within 2 minutes the illuminator times out and returns to the previous mode it was in – either Programming Mode or Operating Mode.

Disabling the Manual Buttons :

If the Illuminator is in Operating Mode, once the disable manual buttons command is executed the buttons will be disabled after 30 minutes. This is to allow the user to re-enable manual buttons if required.

During this 30 minutes the button response will be the following

- LHS Button
 - o Illuminator Settings Mode cannot be accessed. A momentary press of the button will not be recognised and the indicator LEDs will not change
 - o Illuminator Security Mode can be accessed in the normal way by a continuous 4 second press
- RHS Button
 - o Pushing this button will cause both indicator LEDs to flash RED

Once the 30 minutes has expired any button push (LHS or RHS) will cause both indicator LEDs to flash RED and the manual buttons are fully disabled

Disabling the Manual Buttons Using the Remote :

The manual buttons can be disabled using the remote.

Once the illuminator is put into Operating mode if the disable remote control Set Up button (see diagram on Page 8) is pressed again and held for 4 seconds the manual buttons will be disabled. This is shown by both indicator LEDs flashing RED after 4 seconds.

Note : This command can only be used within 5 minutes of the illuminator being put into Operating Mode using the Remote Control

(If the Manual Buttons are already Disabled , both LEDs will flash RED straight away)

Power Up Functionality :

After power is supplied to the unit :

If no PIN is present the Illuminator will go into Programming Mode for 7 Days and then will default to Operating Mode

- During this time if the remote is used to change settings the illuminator will still default into Operating Mode after 7 Days from the power up (unless the remote disable button is used to change the illuminator to Operating Mode)
- During this time if the manual buttons are used in either Illuminator Settings Modes or Illuminator Configuration Modes the Illuminator will default into Operating Mode 30 minutes after the last button press

RESET Options :

There are Two Re-set options for resetting your VARIO2 illuminator

Settings Re-set :

Pressing and holding the RESET BUTTON on the remote control or using the manual buttons to complete a RESET will restore the factory settings to the illuminator. Note : If a PIN is present it will not be removed and the illuminator will return to the mode you were in (Programming or Operating) prior to the re-set command. Both indicator LEDs will flash AMBER when completed.

Full Re-Set :

The other option to reset your illuminator is available by recycling the power whilst holding down the two manual buttons. This is a FULL RESET and will restore factory settings AND remove the PIN if one has been set. Both Indicator LEDs will flash AMBER when completed.

Standard Bracketry :

Supplied with the Product (Model Dependant)

(not to scale, dimensions rounded to nearest mm)

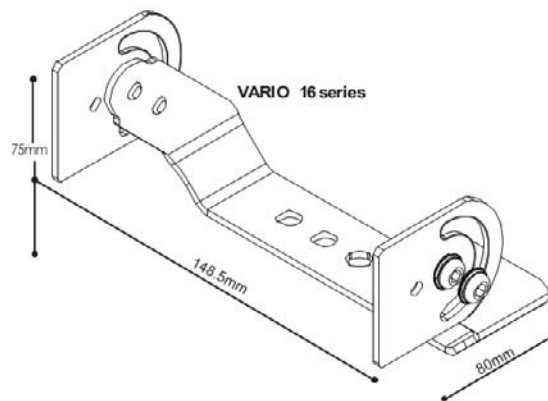
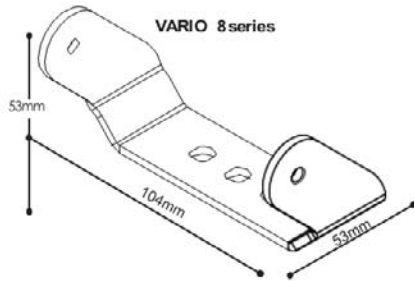
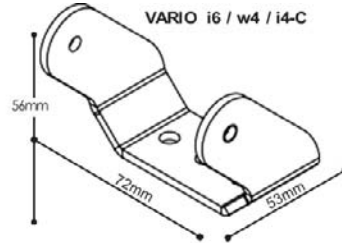
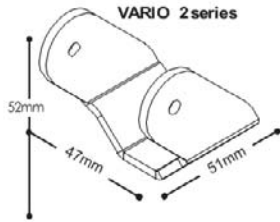

Optional Bracketry (not to scale - other Bracketry also available)

VUB-Pole

VUB-Wall

VUB-Plate

VUB-PSU Plate

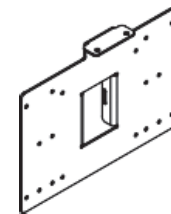
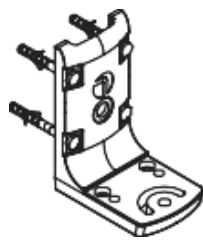

Wall Mount

PTZ Mount

Dome Mount

Pole Mount

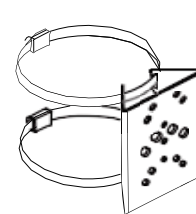
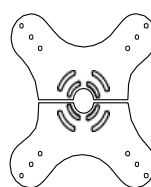
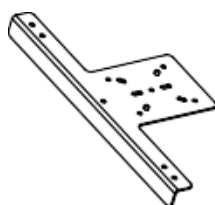
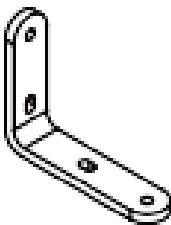

VARIO2 Specifications Table :

Infra-Red Series & White-Light Series

	i16	w16	i8	w8	i6	i4	w4	i2	w2
10°	500m (1640ft)	250m (820ft)	350m (1148ft)	180m (591ft)	200m (656ft)	144m (472ft)	110m (361ft)	78m (256ft)	60m (197ft)
35°	250m (820ft)	125m (410ft)	165m (541ft)	95m (312ft)	120m (394ft)	78m (256ft)	65m (213ft)	54m (177ft)	40m (131ft)
60°	135m (443ft)	70m (230ft)	95m (311ft)	50m (164ft)	70m (230ft)	54m (177ft)	35m (115ft)	36m (118ft)	25m (82ft)
80°	105m (344ft)	48m (157ft)	70m (230ft)	35m (115ft)	50m (164ft)	36m (118ft)	25m (82ft)	24m (79ft)	20m (66ft)
120°	65m (213ft)	35m (115ft)	45m (148ft)	25m (82ft)	30m (98ft)	24m (79ft)	18m (59ft)	18m (59ft)	12m (39ft)
Consumption	100W max	84W max	46W max	42W max	25W max	13W max	24W max	10W max	11W max
Input	24V AC/DC		12-24V AC/DC		12-24V AC/DC			12-24V AC/DC	
Weight	3.1kg (6.8lbs)		1.65kg (3.61lbs)		950g (2.1lbs)			600g (1.3lbs)	
Number of LED's	48		24		12	9	12	6	6
Environment	IP66		IP66		IP66			IP66	
Dimensions	180 x 277 x 75mm 7" x 11" x 2.9"		135 x 180 x 68mm (5" x 7" x 3")		100 x 135 x 66mm 4" x 5" x 2.5"			75 x 100 x 64mm 3" x 4" x 2.5"	
Cable Length	2.5m	2.5m	2.5m	2.5m	2.5m	2.5m	2.5m	2.5m	2.5m

For IR940nm Distances please contact RayLED

- For i16; w16; i8; w8 the supply to the units should be limited to/ fused at 5A
- For i6; w4 the supply to the units should be limited to/ fused at 3.15A
- For i4; i2; w2 the supply to the units should be limited to/ fused at 1.6A

Standards:

CE (Covering EMC, Safety, IP rating)

FCC

IEC/EN 62471 (Photobiological Safety)

VARIO2 Troubleshoot :

Ensure all tests are undertaken by a qualified, trained engineer. Ensure safe working practices are followed at all times.

Step 1: Basics

- Check polarity of illuminator connection red=+ve, black=-ve
- Ensure power is 12-24V AC or DC (For Vario 16 variants : 24V AC or DC only)
- Ensure telemetry wires are shorted out or valid telemetry input (zero volt or TTL) is applied and correctly wired
- Check photocell is working. Cover photocell fully, light should turn on if valid telemetry input. It is sometimes difficult to see Infra-Red illuminators working in high brightness conditions.
- Ensure power supply is suitably rated to product - check page 20 for specifications
- If longer cables used, ensure sufficient voltage is provided to allow for drops across the cable

If OK...

Step 2: Illuminator Test

- Check current is being drawn – amount of current will depend on power setting of unit. Please note – use appropriate multimeter depending on how the unit is being powered (AC or DC)
- To test this you must ensure photocell fully covered (or disabled using optional VARIO remote controller or manual control buttons) and ensure telemetry wires are shorted out or valid telemetry input (zero volt or TTL) is applied and correctly wired

Step 3: Set up camera, lens, and illumination

- Check model number to RayLED performance specification to ensure required distance is achievable;
- Check unit is set to max power
- Check orientation of unit and ensure it is pointing in correct direction
- Check angle of unit (Interchangeable lens) – Too narrow may cause hot spots and the aperture of the camera lens to close down. Too wide and there may be insufficient light on scene and light going where it is not needed.
- Check the LED status indicators for the status of the illuminator.

Programming mode – LHS Green Solid RHS LED flashes AMBER 1 sec on/off

Operating mode – LHS Green Solid

Status LEDs can be turned off in either mode – check if no LEDs visible.

LHS SOLID GREEN:	Power Applied
LHS FLASHING GREEN:	Remote control IR receiver problem
RHS FLASHING AMBER:	Indicates unit is in programming mode
RHS SOLID AMBER:	Indicates that a valid command is being received
LHS FLASHING RED:	Voltage supply problem detected
LHS SOLID RED:	Illuminator fault detected

Note: the if there is a voltage supply error, the LHS RED LED will FLASH RED but extinguish and revert to the standard SOLD GREEN when the correct voltage has been restored.

The fault indications are non latching

- Check unit is responding to remote /Manual Control buttons.
If not..
- Status indicators may be turned off. Turn on with remote or with manual buttons. This can be done even if programming has been disabled

- In extreme sunlight conditions, distance between remote and unit may need to be reduced
- Programming may be disabled. Enter PIN to retrieve control or RESET illuminator using one of the two RESET modes.
- Battery failure. Check battery on remote (CR2025). Test 3 volt battery, replace if necessary. Ensure battery has clean contacts.
- Remote failure. Test with new remote

Step 4: Call RayLED for further assistance

Note down:

- Model and serial number of illuminator
- Camera make and model
- Camera Lens make and model

If the RayLED illuminator or remote control is still not delivering the required performance, please contact us for further assistance:

UK / Europe Tel: +33 4 58 00 15 74

(Note : The light source (LEDs) of this Illuminator is not replaceable. When the unit reaches its end of life the whole Illuminator shall be disposed of and re-cycled where possible.)

RayLED Warranty

Please register your RayLED LED Illuminator(s) for its 5 year warranty by visiting www.rayled.com

rayLED

rayLED

Main Office:

T: +33 4 58 00 15 74

F: +33 9 55 70 03 53

E-mail: sales@rayled.com

www.rayled.com